

DREH-WENDESCHNEIDPLATTEN

Katalog

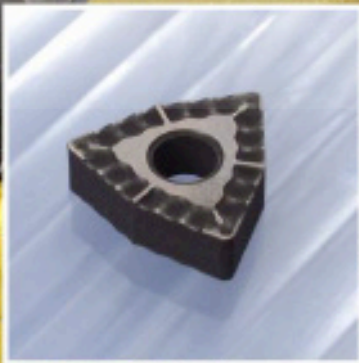
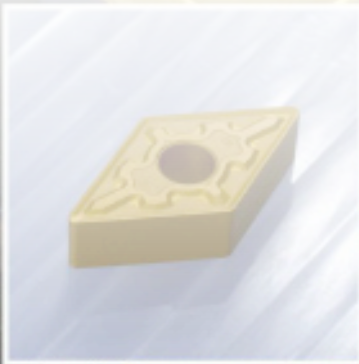

Inserts

Easy grade	A.02
Grades	A.03
Geometries	A.06
Inserts selection	A.10
Code key	A.14
Contents	A.16
ISO Inserts	A.18
Ceramic inserts	F.04
Parting and grooving inserts	G.02
Threading inserts	H.03

Inserts

General turning

Aluminium
wheel turning

Automatic lathes

Ceramic tools

Parting and
grooving

Threading

Drills

Cartridges

Brazed tools

Tooling

Easy grade

Three easy steps to choose a grade.

1st - Select group material (Steel, Stainless steel, Cast iron, Non ferrous materials, heat resistant alloys or hard materials).

2nd - Select suitability. Suitability of each grade is indicated by the height of each material segment.

3rd - Select machining application. Each segment is divided into three sections, each section indicates the machining application type: roughing, medium, finishing. The main application area of each insert is indicated by a black star and the extended applications are indicated by a white star.

1st step

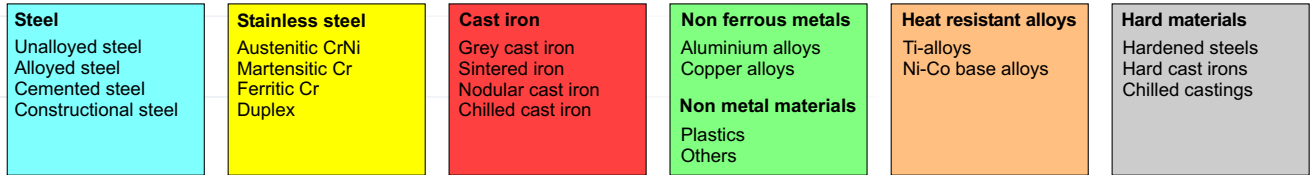

2nd step

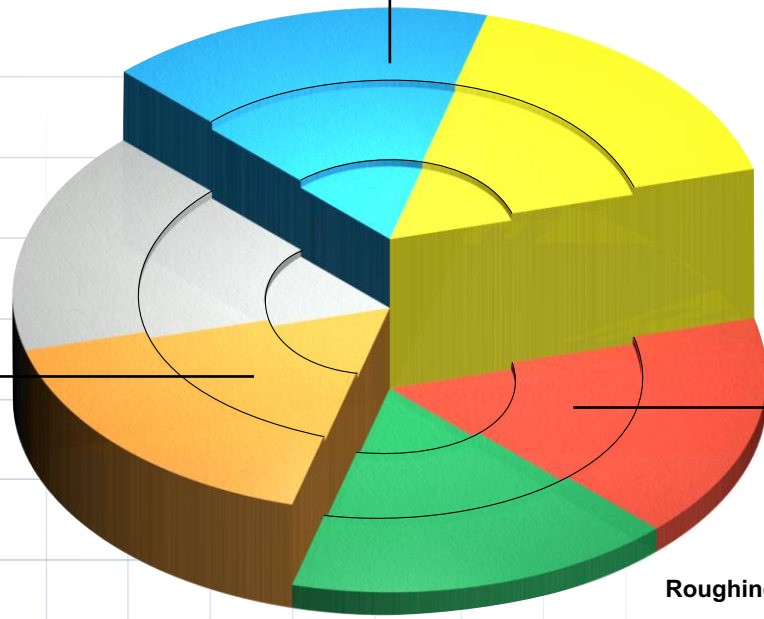

3rd step

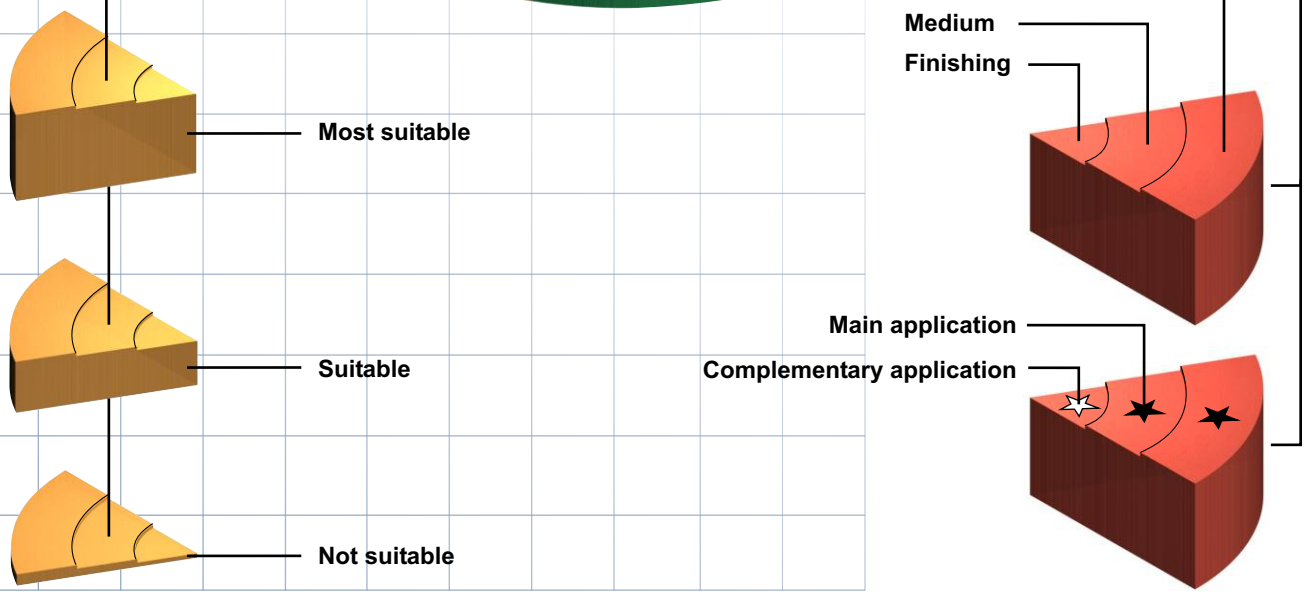

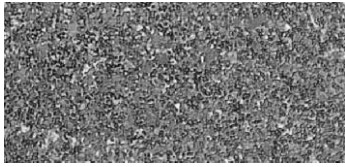

KM 15

Finishing grade in the K10 range. This carbide grade is for use on cast iron, aluminium and heat-resistant alloys. This grade works well on cobalt based alloys and synthetic materials and is suitable for finishing on heat-resistant alloys.



K10

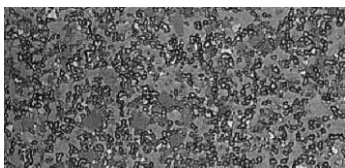
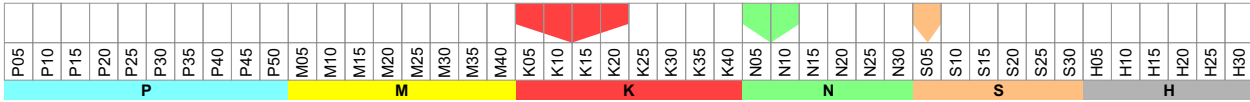

PM 25

General purpose uncoated grade in the P30 range. This tough, economical grade is suitable to work carbon steels, alloyed steels, tool steels and stainless steels. PM25 provides toughness and resistance to deformation in roughing and semi-finishing applications.



P25 - M20

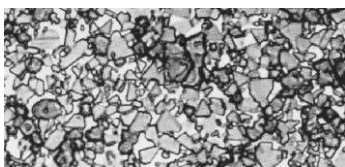
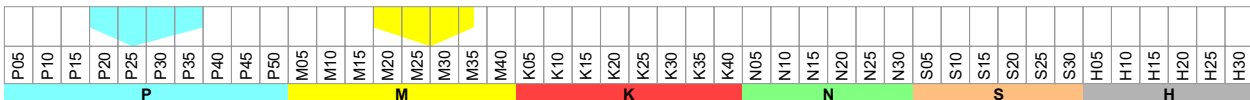

PM 40

Roughing grade in the P35 range. This tough grade is for structural, cast and tool steels. It is recommended when toughness is more important than wear resistance.



P40 - M30

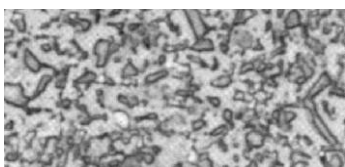
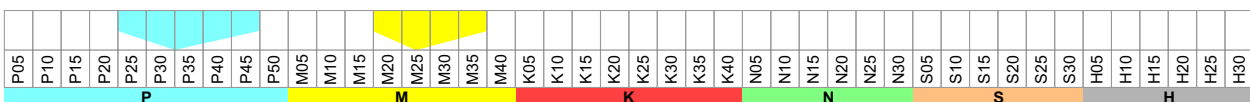

NC 25

NC 25 is a newly developed Cermet applicable for a wide range of cutting conditions as a standard grade for general machining of steel. It can successfully be used for a range of cutting speeds from (100 to 200 m/min) with better wear resistance than conventional TiC Cermet. It gives an excellent performance from semi-finish to finish operation of ductile cast iron at cutting speeds of 200 m/min. or less.



P15 - M10 - K10

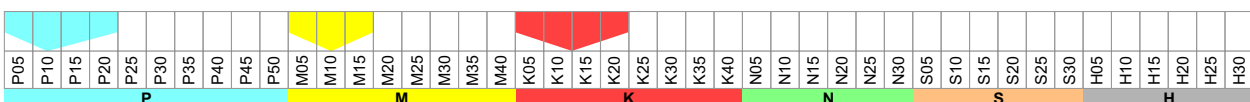

- Inserts
- General turning
- Aluminium wheel turning
- Automatic lathes
- Ceramic tools
- Parting and grooving
- Threading
- Drills
- Cartridges
- Brazed tools
- Tooling

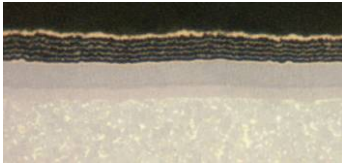

TIN 16

Wear resistant finishing to intermediate grade suitable for many applications on steel, cast iron, stainless steel and high temperature alloys. It is generally used at higher speeds where deformation may be a problem. The multi-layer coating includes TiCN and aluminium oxide.

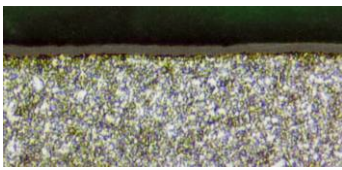
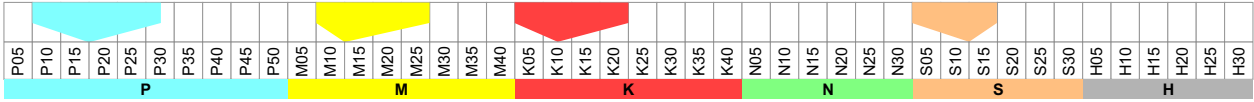
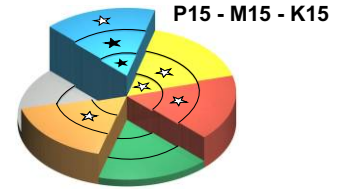

TIN 17

Coated TiAlN grade in the K20 range. This carbide grade is for use on cast iron, aluminium and heat-resistant alloys. This grade works well on cobalt based alloys and synthetic materials and is suitable for finishing on heat-resistant alloys.

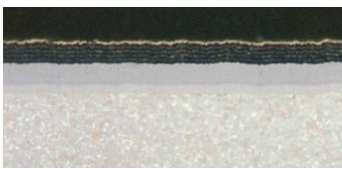
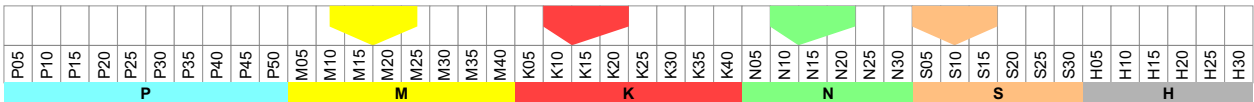
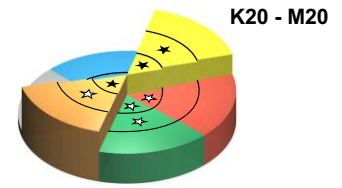

TIN 22

General purpose wear resistant grade. It has enriched substrate which has exceptionally good deformation as well as fracture resistance. The multi-layer coating includes aluminium oxide to add additional heat and wear resistance. It is used to machine steel and stainless steel at lower speeds than TIN16.

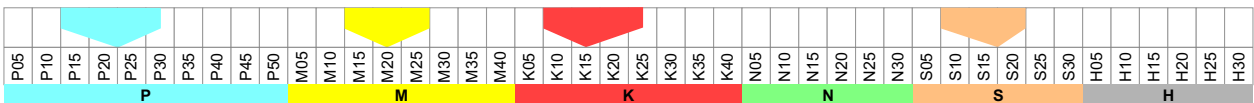

TIN 32

General purpose wear resistant turning grade. The multi-layer coating includes aluminium oxide to add additional heat and wear resistance. It is used to machine steel at lower speeds than TIN16. This turning grade is for demanding metal removal operations, including cutting through scale at low speeds through heavy interruption, and problem machining of stainless steel at low speed and poor rigidity.

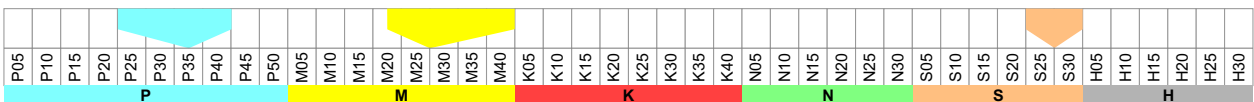



TIN 35

New coated grade developed to machine stainless steel and heat-resistance alloys. This grade is only used in combination with the CS chipbreaker. First choice for stainless steel applications.



M25

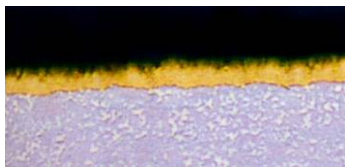
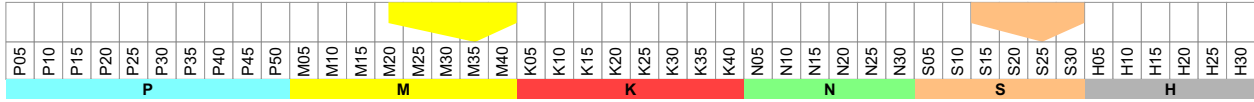

ZR 10

Micrograin grade with an extremely hard single zirconium layer for machining aluminium, copper alloys and plastics.

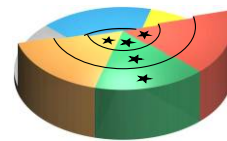

K10

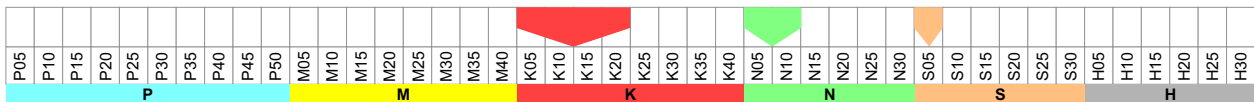

Grade chart



Inserts

General turning

Aluminium wheel turning

Automatic lathes

Ceramic tools

Parting and grooving

Threading

Drills

Cartridges

Brazed tools

Tooling

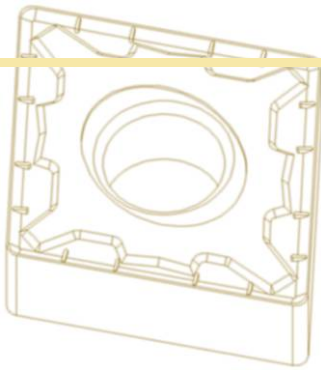

Basic geometries

CF - Finishing

CM - Medium

CR - Roughing

CS - Stainless steel

Complementary geometries

CFC - Finishing Cermet

CFM - Finishing Medium

CMC - Medium Cermet

CMF - Medium Finishing

CMR - Medium Roughing



-CF Geometry

CF chipbreakers are engineered for light finishing operations at high speeds in the 0,08 mm to 0,3 mm feed range at depths of cut between (0,2 to 2,5 mm).

Main application area: Cutting depth (A_p): 0,2 - 2,5 mm
Feed (f): 0,08 - 0,3 mm

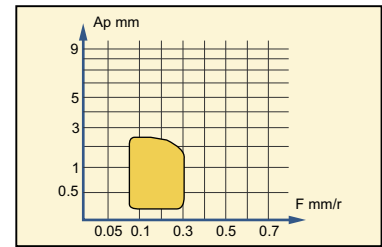

-CM Geometry

CM chipbreakers provide a positive rake angle with land for high edge strength in medium duty applications on a wide range of materials.

Recommended for general purpose use on all types of steel.

Main application area: Cutting depth (A_p): 1,0 - 3,5 mm
Feed (f): 0,15 - 0,35 mm

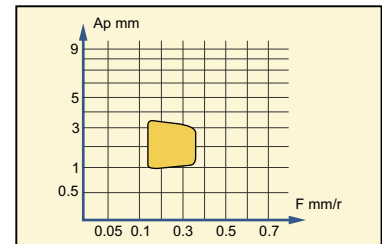

-CR Geometry

The strongest chipbreaker for double-sided inserts. The CR chipbreaker is suitable for high feed rates and depths of cut that normally require single-sided inserts. The chipbreaker has a wide negative T land, which gives high edge strength.

Main application area: Cutting depth (A_p): 1,5 - 5 mm
Feed (f): 0,3 - 0,5 mm

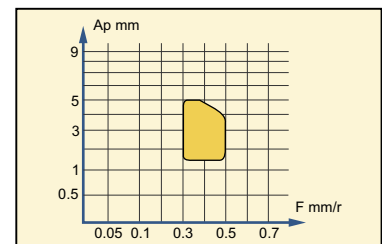

-CS Geometry

First choice for stainless steel. CS chipbreaker provide excellent chip control with low cutting forces.

Main application area: Cutting depth (A_p): 0,5 - 4,0 mm
Feed (f): 0,15 - 0,5 mm

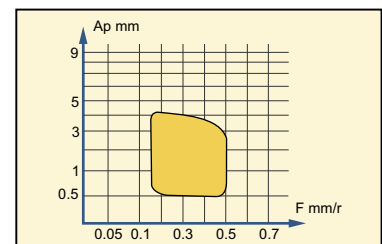



-CFC Geometry

CFC chipbreakers combined with the performance of Cermets provide for efficient chip control in finishing and light machining operations.
Recommended for finishing steels and cast iron.

Main application area: Cutting depth (A_p): 0,2 - 1,5 mm
Feed (f): 0,05 - 0,4 mm

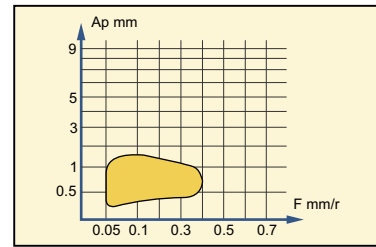

-CFM Geometry

Double sided insert for semi-finishing and light roughing. 12° Positive cutting angle which reduces the cutting forces on the working piece. Chipbreaker with differential profile which reduces the contact zone and so improves thermal diffusion. Excellent performance in steel and materials which work harden.

Main application area: Cutting depth (A_p): 0,5 - 2,5 mm
Feed (f): 0,05 - 0,25 mm

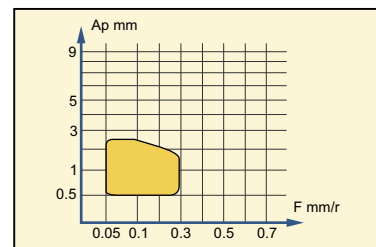

-CMC Geometry

Double sided insert for finishing and light roughing. Positive cutting angle and reinforced edge, which ensures a smooth chip control. Optimum resting surface, which ensures maximum stability and effective thermal dissipation. Special geometry for Cermet inserts.

Main application area: Cutting depth (A_p): 0,3 - 3,0 mm
Feed (f): 0,1 - 0,4 mm

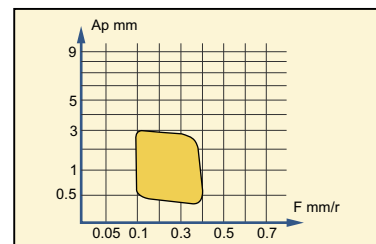

-CMF Geometry

CMF chipbreaker provide excellent chip control with low cutting forces and very free cutting action over a broad range of light duty applications. Recommended for light duty use on carbon, alloy, and stainless steels.

Main application area: Cutting depth (A_p): 0,5 - 4,0 mm
Feed (f): 0,15 - 0,5 mm

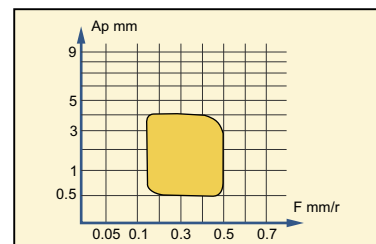

-CMR Geometry

Double sided insert for semi-finishing and light roughing. 12° Positive cutting angle which reduces the cutting forces on the working piece. Chipbreaker with differential profile which reduces the contact zone and so improves thermal diffusion. Excellent performance in steel and materials which work harden.

Main application area: Cutting depth (A_p): 0,5 - 5,0 mm
Feed (f): 0,4 - 0,8 mm

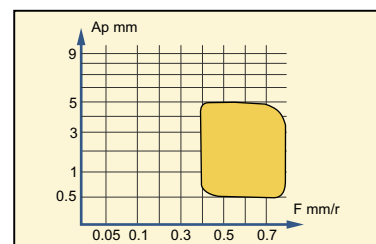



..NGP Geometry

For medium duty machining of tough work materials, above all chrome-nickel based alloys.
Minimises tendency for these materials to adhere to the insert.

Main application area: Cutting depth (A_p): 0,1 - 4 mm
Feed (f): 0,1 - 0,25 mm

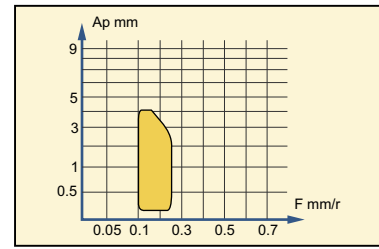

..NMA Geometry

Double sided insert for short chipping materials.
Strong cutting edge.

Main application area: Cutting depth (A_p): 1 - 12 mm
Feed (f): 0,2 - 1 mm

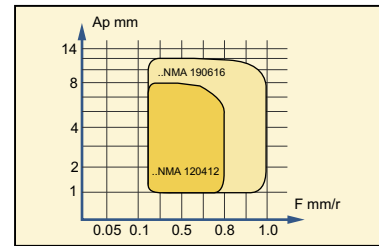

..NMM Geometry

Chipbreaker for single-sided inserts.
It has a positive cutting edge which gives rise to low cutting forces.

Main application area: Cutting depth (A_p): 2,5 - 6 mm
Feed (f): 0,4 - 0,6 mm

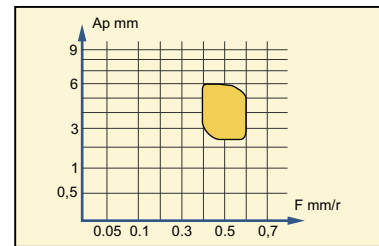

..NMX Geometry

Light duty pos/neg inserts provide excellent chip control in light feed ranges using high positive shear angles.
Recommended for machining of steels and other materials.

Main application area: Cutting depth (A_p): 0,5 - 3 mm
Feed (f): 0,1 - 0,4 mm

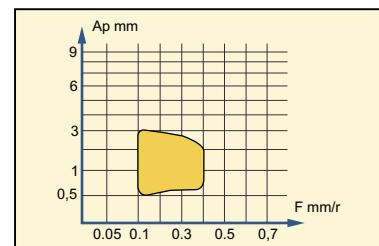



-03 Geometry

Light to medium-duty machining operations. Low cutting forces and reduced power requirements thanks to positive rake angle. Good chip control over a wide range. Also used on short-chipping cast-iron materials.

Main application area: Cutting depth (A_p): 0,5 - 4 mm
Feed (f): 0,15 - 0,4 mm

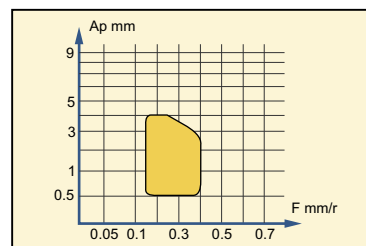

-33 Geometry

Geometry providing chip control in the finishing and medium duty range. Positive rake reduces cutting forces and power consumption. Can also be used on low-strength and stainless steels.

Main application area: Cutting depth (A_p): 0,5 - 4 mm
Feed (f): 0,15 - 0,4 mm

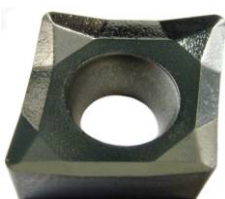
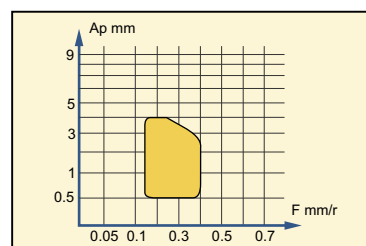

-AL Geometry

Geometry can be used for turning aluminium, light alloys, non ferrous metals, high-melting metals, plastics, glass fiber reinforced plastics, laminated board, carbon and fine ceramics.

Main application area: Cutting depth (A_p): 1 - 10 mm
Feed (f): 0,1 - 0,75 mm

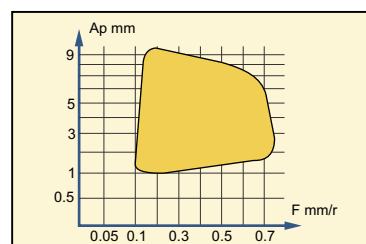

-AP Geometry

Geometry can be used for turning aluminium, light alloys, non ferrous metals, high-melting metals, plastics, glass fiber reinforced plastics, laminated board, carbon and fine ceramics.

Main application area: Cutting depth (A_p): 0,5 - 8 mm
Feed (f): 0,1 - 0,7 mm

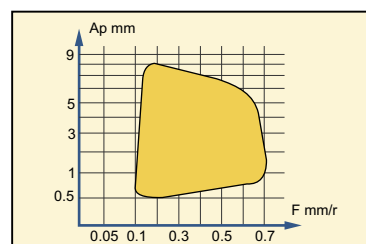

..MW Geometry

Double sided insert for short chipping materials. Strong cutting edge.

Main application area: Cutting depth (A_p): 0,2 - 4 mm
Feed (f): 0,1 - 0,3 mm

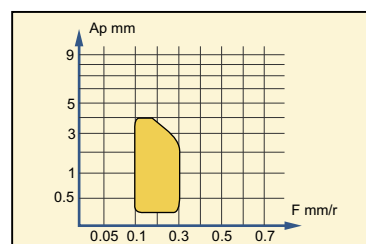

Basic geometries (steel)

1 - Select geometry

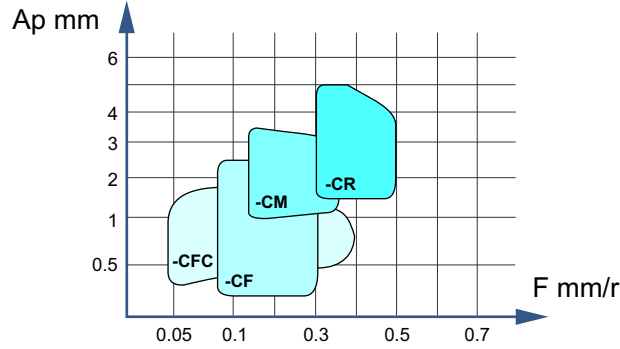

2 - Select grade

Cutting condition

	▼▼▼▼ Super finishing	▼▼▼ Finishing	▼▼ Medium machining	▼ Roughing
⊗ Interrupted cut	-	TIN32	TIN32	PM25 - TIN32
⊖ Inconsistent cut	NC25	TIN16	TIN16 - TIN22	TIN22 - TIN32
⊙ Consistent cut	NC25	TIN16	TIN16	TIN22 - TIN32

3 - Select cutting speed

Proceed to page B.77 for cutting data

Complementary geometries (steel)

1 - Select geometry

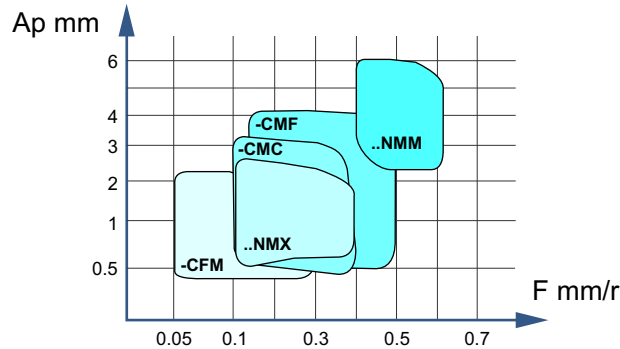
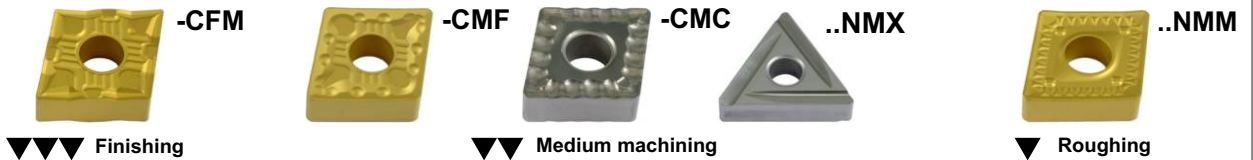

2 - Select grade

Cutting condition

	▼▼▼ Finishing	▼▼ Medium machining	▼ Roughing
⊗ Interrupted cut	TIN32	TIN32	TIN32
⊖ Inconsistent cut	TIN16 - TIN32	NC25 - TIN22 - TIN32	TIN32
⊙ Consistent cut	TIN16	NC25 - TIN16 - TIN32	TIN32

3 - Select cutting speed

Proceed to page B.77 for cutting data

Basic geometries (Stainless steel)

1 - Select geometry



-CFC

▼▼▼▼ Super finishing



-CF

▼▼▼ Finishing



-CS

▼▼ Medium machining



-CS

▼ Roughing

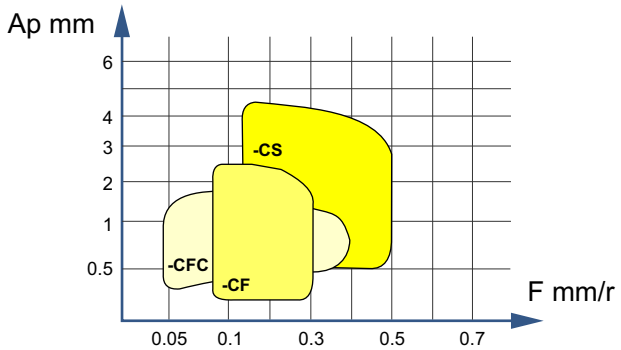

Graph showing A_p (mm) vs F (mm/r) for basic geometries. The y-axis ranges from 0.5 to 6 mm, and the x-axis ranges from 0.05 to 0.7 mm/r. The regions are: -CFC (low A_p , low F), -CF (low to medium A_p , low to medium F), and -CS (medium to high A_p , medium to high F).

2 - Select grade

Cutting condition	Super finishing	Finishing	Medium machining	Roughing
⊗ Interrupted cut	-	TIN32 - TIN35	TIN32 - TIN35	TIN35
⊖ Inconsistent cut	NC25	TIN16 - TIN32 - TIN35	TIN32 - TIN35	TIN35
⊙ Consistent cut	NC25	TIN16 - TIN32 - TIN35	TIN32 - TIN35	TIN35

3 - Select cutting speed

Proceed to page B.77 for cutting data

Complementary geometries (Stainless steel)

1 - Select geometry



-CFM

▼▼▼ Finishing



..NGP



-CMF

▼▼ Medium machining



..NGP

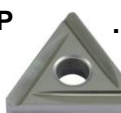

..NMX

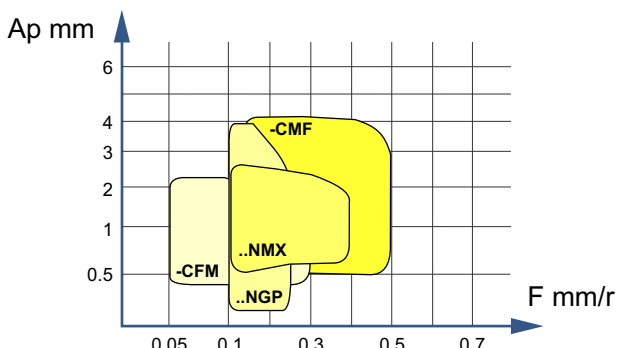

Graph showing A_p (mm) vs F (mm/r) for complementary geometries. The y-axis ranges from 0.5 to 6 mm, and the x-axis ranges from 0.05 to 0.7 mm/r. The regions are: -CFM (low A_p , low F), ..NGP (low to medium A_p , low to medium F), and -CMF (medium to high A_p , medium to high F).

2 - Select grade

Cutting condition	Finishing	Medium machining
⊗ Interrupted cut	TIN32	TIN32
⊖ Inconsistent cut	TIN17 - TIN32	NC25 - TIN17 - TIN32
⊙ Consistent cut	TIN17 - TIN32	NC25 - TIN17 - TIN32

3 - Select cutting speed

Proceed to page B.77 for cutting data

- Inserts
- General turning
- Aluminum wheel turning
- Automatic lathes
- Ceramic tools
- Parting and grooving
- Threading
- Drills
- Cartridges
- Brazed tools
- Tooling

Basic geometries (Cast iron)

1 - Select geometry



-CFC

▼▼▼▼ Super finishing



-CF

▼▼▼ Finishing



..NMA

▼▼ Medium machining



-CM



..NMA

▼ Roughing

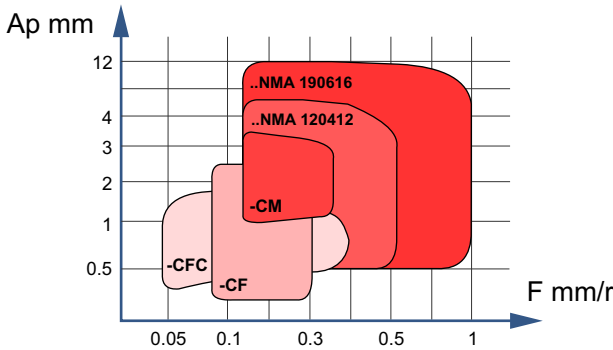

Graph showing Ap (mm) vs F (mm/r) for basic geometries. The y-axis ranges from 0.5 to 12 mm, and the x-axis ranges from 0.05 to 1 mm. The regions are: -CFC (0.05-0.1, 0.5-1.5), -CF (0.1-0.3, 0.5-2), -CM (0.1-0.5, 0.5-4), ..NMA 120412 (0.1-0.5, 1-12), and ..NMA 190616 (0.1-1, 1-12).

2 - Select grade

Cutting condition	▼▼▼▼ Super finishing	▼▼▼ Finishing	▼▼ Medium machining	▼ Roughing
	⊗ Interrupted cut	-	TIN16	TIN16 - TIN17
⊖ Inconsistent cut	NC25	TIN16	TIN16 - TIN17	TIN16 - TIN17
⊙ Consistent cut	NC25	TIN16	TIN16 - TIN17	TIN16 - TIN17

3 - Select cutting speed

Proceed to page B.77 for cutting data

Complementary geometries (Cast iron)

1 - Select geometry



..NGP

▼▼▼ Finishing



-CMF



..NMX

▼▼ Medium machining



..NGP

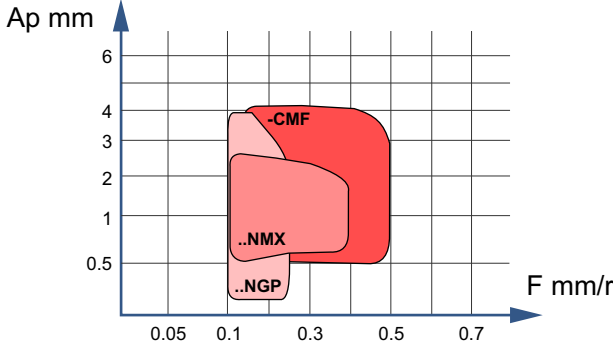

Graph showing Ap (mm) vs F (mm/r) for complementary geometries. The y-axis ranges from 0.5 to 6 mm, and the x-axis ranges from 0.05 to 0.7 mm. The regions are: ..NGP (0.1-0.3, 0.5-1.5), ..NMX (0.1-0.5, 0.5-3), and -CMF (0.1-0.5, 1-4).

2 - Select grade

Cutting condition	▼▼▼ Finishing	▼▼ Medium machining
	⊗ Interrupted cut	TIN16 - TIN17
⊖ Inconsistent cut	NC25 - TIN16 - TIN17	NC25 - TIN16 - TIN17
⊙ Consistent cut	NC25 - TIN16 - TIN17	NC25 - TIN16 - TIN17

3 - Select cutting speed

Proceed to page B.77 for cutting data

Basic geometries (Non ferrous materials)

1 - Select geometry

▼▼▼ Finishing ▼▼ Medium machining ▼ Roughing

Positive inserts

2 - Select grade

Cutting condition	Finishing	Medium machining	Roughing
☉ Interrupted cut	KM15 - TIN16 - TIN17 - ZR10	NC25 - TIN17 - ZR10	NC25 - TIN17 - ZR10
⊖ Inconsistent cut	KM15 - TIN16 - TIN17 - ZR10	NC25 - TIN17 - ZR10	NC25 - TIN17 - ZR10
⊙ Consistent cut	KM15 - TIN16 - TIN17 - ZR10	NC25 - TIN17 - ZR10	NC25 - TIN17 - ZR10

3 - Select cutting speed

Proceed to page B.77 for cutting data

- Inserts
- General turning
- Aluminium wheel turning
- Automatic lathes
- Ceramic tools
- Parting and grooving
- Threading
- Drills
- Cartridges
- Brazed tools
- Tooling

Basic geometries (Heat resistant alloys)

1 - Select geometry

▼▼▼ Finishing ▼▼ Medium machining ▼ Roughing

2 - Select grade

Cutting condition	Finishing	Medium machining	Roughing
☉ Interrupted cut	TIN17	TIN17 - TIN32 - TIN35	TIN35
⊖ Inconsistent cut	TIN17	TIN17 - TIN32 - TIN35	TIN35
⊙ Consistent cut	TIN17	TIN17 - TIN32 - TIN35	TIN35

3 - Select cutting speed

Proceed to page B.77 for cutting data

Insert shape		
	35°	V
	55°	D
	75°	E
	80°	C
	86°	M
	55°	K
	82°	B
	85°	A
	90°	L
	108°	P
	120°	H
	135°	O
	-	R
	90°	S
	60°	T
	80°	W

Clearance angle		
	3°	A
	5°	B
	7°	C
	15°	D
	20°	E
	25°	F
	30°	G
	0°	N
	11°	P
	Clearance angles not included with in the standard for which particular information is necessary.	

Tolerances			
0,025	0,005	0,025	A
0,013	0,005	0,025	F
0,025	0,013	0,025	C
0,013	0,013	0,025	H
0,025	0,025	0,025	E
0,025	0,025	0,13	G
0,05-0,15	0,005	0,025	J
0,05-0,15	0,013	0,025	K
0,05-0,15	0,025	0,025	L
0,05-0,15	0,08-0,20	0,13	M
0,05-0,15	0,08-0,20	0,025	N
0,08-0,25	0,13-0,38	0,13	U

Form of top surface	
	N
	R
	F
	A
	M
	G
	W
	T
	Q
	U
	B
	H
	C
	J
Special version	X

C

N

M

G

A	0,0010	0,0002	0,001
F	0,0005	0,0002	0,001
C	0,0010	0,0005	0,001
H	0,0005	0,0005	0,001
E	0,0010	0,0010	0,001
G	0,0010	0,0010	0,005
J	0,002 to 0,006*	0,0002	0,001
K	0,002 to 0,006*	0,0005	0,001
L	0,002 to 0,006*	0,0010	0,001
M	0,002 to 0,006*	0,003 to 0,008*	0,005
N	0,002 to 0,006*	0,003 to 0,008*	0,001
U	0,003 to 0,010*	0,005 to 0,015*	0,005

d m s

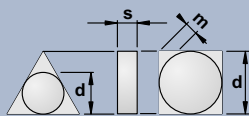

* Depends on insert size

Tolerance (inches)

N / R / F	E
A / M / G	D
X	X
IK > 1/4"	IK < 1/4"

Symbols as above
Changes at inscribed circle IK < 1/4"

Form of top surface

Edge cutting length			
06	5/32	3,96	03
09	7/32	5,56	05
11	1/4	6,35	06
16	3/8	9,52	09
22	1/2	12,7	12
27	5/8	15,8	15
33	3/4	19,0	19
44	1	25,4	25
mm	mm	inch	mm
06	10	16	25
08	12	20	32

Insert thickness		
1/16	1,59	01
3/32	2,38	02
1/8	3,18	03
5/32	3,97	T3
3/16	4,76	04
7/32	5,56	05
1/4	6,35	06
5/16	7,94	07
3/8	9,52	09
inch	mm	

Corner radius			
00	0,0	12	1,2
M0	0,0	16	1,6
02	0,2	20	2,0
04	0,4	24	2,4
08	0,8	32	3,2
Inserts with corner radius			
Inserts with secondary cutting edge			
A	45°	F	85°
D	60°	P	90°
E	75°		
Angle of main cutting edge to secondary cutting angle			
A	3°	F	25°
B	5°	G	30°
C	7°	N	0°
D	15°	P	11°
E	20°	Z	Special
Clearance angle			

Cutting edge	
F	Sharp
E	Honed
T	Chamfered
S	Chamfered and honed
K	Double-chamfered
P	Double-chamfered and honed

Cutting direction	
R	
L	
N	

12

04

08

4

3

2

1/4	2
3/8	3
1/2	4
5/8	5
3/4	6
1	8

Cutting edge length (inch)























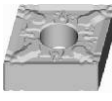





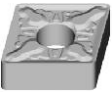



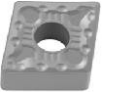





















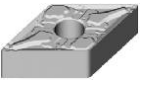



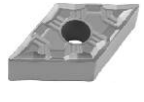

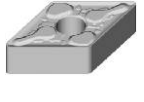







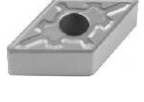

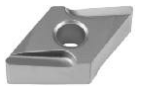

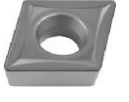





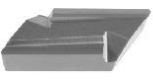

1/16	1
1/8	2
3/16	3
1/4	4
5/16	5
3/8	6















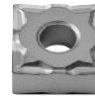



























Insert thickness (inch)

max. 0,004	0
1/64	1
1/32	2
3/64	3
1/16	4
5/64	5
3/32	6
7/64	7
1/8	8
-	X

Corner radius (inch)

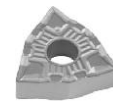
For special forms of the chip groove in the 10° position manufacturer specific chip grooves and designations can be indicated.

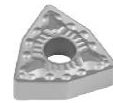
<p>CCGT-AL</p>  <p>80° Rhombic Positive Page A.18 </p>	<p>CCGT-AP</p>  <p>80° Rhombic Positive Page A.18 </p>	<p>CCMT-03</p>  <p>80° Rhombic Positive Page A.18 </p>	<p>CCMW</p>  <p>80° Rhombic Positive Page A.18 </p>	<p>CNGP</p>  <p>80° Rhombic Negative Page A.18 </p>	<p>CNMA</p>  <p>80° Rhombic Negative Page A.19 </p>	<p>CNMG-CF</p>  <p>80° Rhombic Negative Page A.19 </p>
<p>CNMG-CFC</p>  <p>80° Rhombic Negative Page A.19 </p>	<p>CNMG-CFM</p>  <p>80° Rhombic Negative Page A.19 </p>	<p>CNMG-CM</p>  <p>80° Rhombic Negative Page A.19 </p>	<p>CNMG-CMC</p>  <p>80° Rhombic Negative Page A.20 </p>	<p>CNMG-CMF</p>  <p>80° Rhombic Negative Page A.20 </p>	<p>CNMG-CMR</p>  <p>80° Rhombic Negative Page A.20 </p>	<p>CNMG-CR</p>  <p>80° Rhombic Negative Page A.20 </p>
<p>CNMG-CS</p>  <p>80° Rhombic Negative Page A.20 </p>	<p>CNMM</p>  <p>80° Rhombic Negative Page A.21 </p>					
<p>DCGT-AL</p>  <p>55° Rhombic Positive Page A.21 </p>	<p>DCGT-AP</p>  <p>55° Rhombic Positive Page A.21 </p>	<p>DCMT-03</p>  <p>55° Rhombic Positive Page A.21 </p>	<p>DCMW</p>  <p>55° Rhombic Positive Page A.21 </p>	<p>DNGP</p>  <p>55° Rhombic Negative Page A.22 </p>	<p>DNMA</p>  <p>55° Rhombic Negative Page A.22 </p>	<p>DNMG-CF</p>  <p>55° Rhombic Negative Page A.22 </p>
<p>DNMG-CFC</p>  <p>55° Rhombic Negative Page A.22 </p>	<p>DNMG-CFM</p>  <p>55° Rhombic Negative Page A.22 </p>	<p>DNMG-CM</p>  <p>55° Rhombic Negative Page A.23 </p>	<p>DNMG-CMC</p>  <p>55° Rhombic Negative Page A.23 </p>	<p>DNMG-CMF</p>  <p>55° Rhombic Negative Page A.23 </p>	<p>DNMG-CMR</p>  <p>55° Rhombic Negative Page A.23 </p>	<p>DNMG-CS</p>  <p>55° Rhombic Negative Page A.23 </p>
<p>DNMX</p>  <p>55° Rhombic Negative Page A.24 </p>						
<p>ECMT</p>  <p>75° Rhombic Positive Page A.24 </p>	<p>EPMT</p>  <p>75° Rhombic Positive Page A.24 </p>	<p>EPMW</p>  <p>75° Rhombic Positive Page A.24 </p>	<p>EPMX</p>  <p>75° Rhombic Positive Page A.24 </p>			<p>GXGP-AL</p>  <p>Double-ended Page A.25</p>
<p>KNUX</p>  <p>KNUX Negative Page A.24 </p>			<p>RCGT-AL</p>  <p>Round Positive Page A.25 </p>	<p>RCGT-AP</p>  <p>Round Positive Page A.25 </p>	<p>RCMT</p>  <p>Round Positive Page A.25 </p>	<p>RNMG</p>  <p>Round Negative Page A.26 </p>

<p>SCGT-AL</p>  <p>Square Positive Page A.26 7°</p>	<p>SCMT-03</p>  <p>Square Positive Page A.26 7°</p>	<p>SCMT-39</p>  <p>Square Positive Page A.26 7°</p>	<p>SCMW</p>  <p>Square Positive Page A.26 7°</p>	<p>SNMA</p>  <p>Square Negative Page A.27 0°</p>	<p>SNMG-CFM</p>  <p>Square Negative Page A.27 0°</p>	<p>SNMG-CMR</p>  <p>Square Negative Page A.27 0°</p>
<p>SNMG-CR</p>  <p>Square Negative Page A.27 0°</p>	<p>SNMM</p>  <p>Square Negative Page A.27 0°</p>	<p>SPMR-33</p>  <p>Square Positive Page A.28 11°</p>	<p>SPMT</p>  <p>Square Positive Page A.28 11°</p>	<p>SPUN</p>  <p>Square Positive Page A.28 11°</p>		
<p>TCGT-AL</p>  <p>Triangular Positive Page A.28 7°</p>	<p>TCMT-03</p>  <p>Triangular Positive Page A.28 7°</p>	<p>TCMW</p>  <p>Triangular Positive Page A.29 7°</p>	<p>TNMA</p>  <p>Triangular Negative Page A.29 0°</p>	<p>TNMG-CF</p>  <p>Triangular Negative Page A.29 0°</p>	<p>TNMG-CFC</p>  <p>Triangular Negative Page A.29 0°</p>	<p>TNMG-CFM</p>  <p>Triangular Negative Page A.29 0°</p>
<p>TNMG-CM</p>  <p>Triangular Negative Page A.30 0°</p>	<p>TNMG-CMC</p>  <p>Triangular Negative Page A.30 0°</p>	<p>TNMG-CMF</p>  <p>Triangular Negative Page A.30 0°</p>	<p>TNMG-CMR</p>  <p>Triangular Negative Page A.30 0°</p>	<p>TNMG-CS</p>  <p>Triangular Negative Page A.30 0°</p>	<p>TNMX</p>  <p>Triangular Positive Page A.31 11°</p>	<p>TPMN</p>  <p>Triangular Positive Page A.31 11°</p>
<p>TPMR-33</p>  <p>Triangular Positive Page A.31 11°</p>	<p>TPUN</p>  <p>Triangular Positive Page A.31 11°</p>	<p>TPUX</p>  <p>Triangular Negative Page A.32 11°</p>				
<p>VBMT</p>  <p>35° Rhombic Positive Page A.32 5°</p>	<p>VCGT-AL</p>  <p>35° Rhombic Positive Page A.32 7°</p>	<p>VCGT-AP</p>  <p>35° Rhombic Positive Page A.32 7°</p>	<p>VCMT-03</p>  <p>35° Rhombic Positive Page A.32 7°</p>	<p>VNGP</p>  <p>35° Rhombic Negative Page A.33 0°</p>	<p>VNMG</p>  <p>35° Rhombic Negative Page A.33 0°</p>	<p>VNMG-CMC</p>  <p>35° Rhombic Negative Page A.33 0°</p>
<p>WCMT</p>  <p>80° Trigon Positive Page A.33 7°</p>	<p>WCMX</p>  <p>80° Trigon Positive Page A.33 7°</p>	<p>WNMA</p>  <p>80° Trigon Negative Page A.34 0°</p>	<p>WNMG-CF</p>  <p>80° Trigon Negative Page A.34 0°</p>	<p>WNMG-CFM</p>  <p>80° Trigon Negative Page A.34 0°</p>	<p>WNMG-CM</p>  <p>80° Trigon Negative Page A.34 0°</p>	<p>WNMG-CMC</p>  <p>80° Trigon Negative Page A.34 0°</p>
<p>WNMG-CMF</p>  <p>80° Trigon Negative Page A.35 0°</p>	<p>WNMG-CMR</p>  <p>80° Trigon Negative Page A.35 0°</p>	<p>WNMG-CS</p>  <p>80° Trigon Negative Page A.35 0°</p>				

Inserts
General turning
Aluminum wheel turning
Automatic lathes
Ceramic tools
Parting and grooving
Threading
Drills
Cartridges
Brazed tools
Tooling

Positive 7° clearance - 80° rhombic insert.

Normally available for immediate delivery ●
Only available in a limited quantity ○

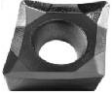
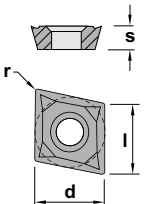
		CCGT-AL	l	s	d	r	KM15	PM25	PM40	NC25	TIN16	TIN17	TIN22	TIN32	TIN35	ZR10
 	CCGT 060202-AL	6,45	2,38	6,35	0,2	●										○
	CCGT 060204-AL	6,45	2,38	6,35	0,4	●										○
	CCGT 09T302-AL	9,65	3,97	9,52	0,2	●										○
	CCGT 09T304-AL	9,65	3,97	9,52	0,4	●										○
	CCGT 09T308-AL	9,65	3,97	9,52	0,8	●										○
	CCGT 120402-AL	12,90	4,76	12,70	0,2	●										○
	CCGT 120404-AL	12,90	4,76	12,70	0,4	●										○
	CCGT 120408-AL	12,90	4,76	12,70	0,8	●										○

Positive 7° clearance - 80° rhombic insert.

Normally available for immediate delivery ●
Only available in a limited quantity ○

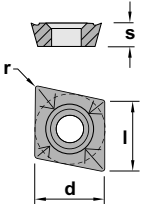
		CCGT-AP	l	s	d	r	KM15	PM25	PM40	NC25	TIN16	TIN17	TIN22	TIN32	TIN35	ZR10
 	CCGT 060202-AP	6,45	2,38	6,35	0,2	●										○
	CCGT 060204-AP	6,45	2,38	6,35	0,4	●										○
	CCGT 09T302-AP	9,65	3,97	9,52	0,2	●										○
	CCGT 09T304-AP	9,65	3,97	9,52	0,4	●										○
	CCGT 09T308-AP	9,65	3,97	9,52	0,8	●										○
	CCGT 120402-AP	12,90	4,76	12,70	0,2	●										○
	CCGT 120404-AP	12,90	4,76	12,70	0,4	●										○
	CCGT 120408-AP	12,90	4,76	12,70	0,8	●										○

Positive 7° clearance - 80° rhombic insert.

Normally available for immediate delivery ●
Only available in a limited quantity ○

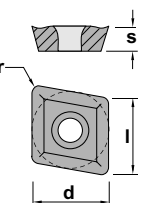
		CCMT-03	l	s	d	r	KM15	PM25	PM40	NC25	TIN16	TIN17	TIN22	TIN32	TIN35	ZR10
 	CCMT 060202-03	6,45	2,38	6,35	0,2	●		●			●					○
	CCMT 060204-03	6,45	2,38	6,35	0,4	●	●	●		●	●			●	●	○
	CCMT 080304-03	8,05	3,18	7,94	0,4	●	●	●		●	●					○
	CCMT 080308-03	8,05	3,18	7,94	0,8	●	●	●		●	●					○
	CCMT 09T304-03	9,65	3,97	9,52	0,4	●	●	○		●	●			●	●	○
	CCMT 09T308-03	9,65	3,97	9,52	0,8	●	●	○		●	●			●	●	○
	CCMT 120408-03	12,90	4,76	12,70	0,8	●	●	○		●	●			●	●	○

Positive 7° clearance - 80° rhombic insert.

Normally available for immediate delivery ●
Only available in a limited quantity ○

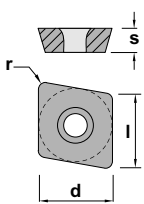
		CCMW	l	s	d	r	KM15	PM25	PM40	NC25	TIN16	TIN17	TIN22	TIN32	TIN35	ZR10
 	CCMW 060202	6,45	2,38	6,35	0,2			●								
	CCMW 060204	6,45	2,38	6,35	0,4			●								
	CCMW 080304	8,05	3,18	7,94	0,4			●								
	CCMW 09T304	9,65	3,97	9,52	0,4			●								
	CCMW 09T308	9,65	3,97	9,52	0,8			●								
	CCMW 120408	12,90	4,76	12,70	0,8			●								

Negative 80° rhombic insert.

Normally available for immediate delivery ●
Only available in a limited quantity ○

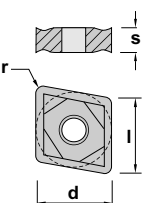
		CNGP	l	s	d	r	KM15	PM25	PM40	NC25	TIN16	TIN17	TIN22	TIN32	TIN35	ZR10
 	CNGP 120404	12,90	4,76	12,70	0,4							●				
	CNGP 120408	12,90	4,76	12,70	0,8							●				

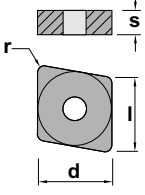
	Negative 80° rhombic insert.						Normally available for immediate delivery ● Only available in a limited quantity ○									
	CNMA	l	s	d	r	KM15	PM25	PM40	NC25	TIN16	TIN17	TIN22	TIN32	TIN35	ZR10	
	CNMA 120408	12,90	4,76	12,70	0,8	●					●					
	CNMA 120412	12,90	4,76	12,70	1,2						○					

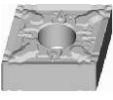
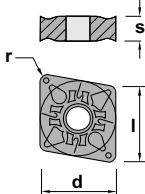
	Negative 80° rhombic insert.						Normally available for immediate delivery ● Only available in a limited quantity ○									
	CNMG-CF	l	s	d	r	KM15	PM25	PM40	NC25	TIN16	TIN17	TIN22	TIN32	TIN35	ZR10	
	CNMG 120404-CF	12,90	4,76	12,70	0,4					●			●			

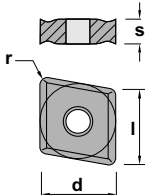
	Negative 80° rhombic insert.						Normally available for immediate delivery ● Only available in a limited quantity ○									
	CNMG-CFC	l	s	d	r	KM15	PM25	PM40	NC25	TIN16	TIN17	TIN22	TIN32	TIN35	ZR10	
	CNMG 120404-CFC	12,90	4,76	12,70	0,4				●							

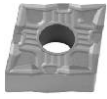
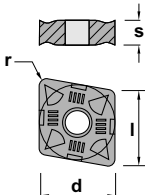
	Negative 80° rhombic insert.						Normally available for immediate delivery ● Only available in a limited quantity ○									
	CNMG-CFM	l	s	d	r	KM15	PM25	PM40	NC25	TIN16	TIN17	TIN22	TIN32	TIN35	ZR10	
	CNMG 120404-CFM	12,90	4,76	12,70	0,4					●						

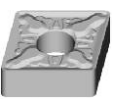
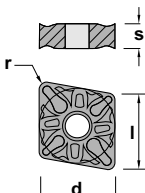
	Negative 80° rhombic insert.						Normally available for immediate delivery ● Only available in a limited quantity ○									
	CNMG-CM	l	s	d	r	KM15	PM25	PM40	NC25	TIN16	TIN17	TIN22	TIN32	TIN35	ZR10	
	CNMG 120408-CM	12,90	4,76	12,70	0,8					●			●			

- Inserts
- General turning
- Aluminum wheel turning
- Automatic lathes
- Ceramic tools
- Parting and grooving
- Threading
- Drills
- Cartridges
- Brazed tools
- Tooling

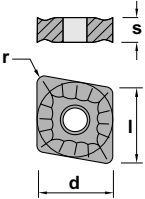
	Negative 80° rhombic insert					Normally available for immediate delivery ● Only available in a limited quantity ○													
	CNMG-CMC					l	s	d	r	KM15	PM25	PM40	NC25	TIN16	TIN17	TIN22	TIN32	TIN35	ZR10
	CNMG 120408-CMC	12,90	4,76	12,70	0,8							●							

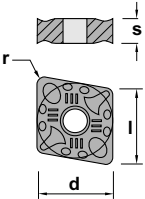
	Negative 80° rhombic insert					Normally available for immediate delivery ● Only available in a limited quantity ○													
	CNMG-CMF					l	s	d	r	KM15	PM25	PM40	NC25	TIN16	TIN17	TIN22	TIN32	TIN35	ZR10
	CNMG 120408-CMF	12,90	4,76	12,70	0,8								●			●			

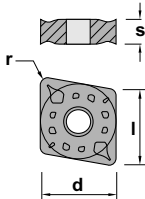
	Negative 80° rhombic insert.					Normally available for immediate delivery ● Only available in a limited quantity ○													
	CNMG-CMR					l	s	d	r	KM15	PM25	PM40	NC25	TIN16	TIN17	TIN22	TIN32	TIN35	ZR10
	CNMG 090304-CMR	9,65	3,18	9,52	0,4								●						
	CNMG 090308-CMR	9,65	3,18	9,52	0,8										●				
	CNMG 120408-CMR	12,90	4,76	12,70	0,8				●				●		●	●			
	CNMG 120412-CMR	12,90	4,76	12,70	1,2										●				

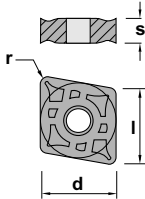
	Negative 80° rhombic insert.					Normally available for immediate delivery ● Only available in a limited quantity ○													
	CNMG-CR					l	s	d	r	KM15	PM25	PM40	NC25	TIN16	TIN17	TIN22	TIN32	TIN35	ZR10
	CNMG 120408-CR	12,90	4,76	12,70	0,8												●		
	CNMG 120412-CR	12,90	4,76	12,70	1,2												●		
	CNMG 160608-CR	16,10	6,35	15,88	0,8												○		
	CNMG 160612-CR	16,10	6,35	15,88	1,2												○		
	CNMG 190612-CR	19,30	6,35	19,05	1,2												○		
	CNMG 190616-CR	19,30	6,35	19,05	1,6												○		

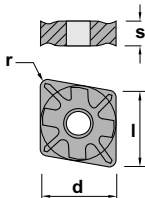
	Negative 80° rhombic insert.					Normally available for immediate delivery ● Only available in a limited quantity ○													
	CNMG-CS					l	s	d	r	KM15	PM25	PM40	NC25	TIN16	TIN17	TIN22	TIN32	TIN35	ZR10
	CNMG 090304-CS	9,65	3,18	9,52	0,4													●	
	CNMG 090308-CS	9,65	3,18	9,52	0,8														●
	CNMG 120404-CS	12,90	4,76	12,70	0,4														●
	CNMG 120408-CS	12,90	4,76	12,70	0,8														●

Negative 80° rhombic insert.

Normally available for immediate delivery ●
Only available in a limited quantity ○

CNMM	l	s	d	r	KM15	PM25	PM40	NC25	TiN16	TiN17	TiN22	TiN32	TiN35	ZR10
CNMM 120408	12,90	4,76	4,76	0,8								○		
CNMM 120412	12,90	4,76	4,76	1,2								○		
CNMM 160612	16,10	6,35	6,35	1,2								○		
CNMM 190608	19,30	6,35	6,35	0,8								○		
CNMM 190612	19,30	6,35	6,35	1,2								○		

Positive 7° clearance - 55° rhombic insert.

Normally available for immediate delivery ●
Only available in a limited quantity ○

DCGT-AL	l	s	d	r	KM15	PM25	PM40	NC25	TiN16	TiN17	TiN22	TiN32	TiN35	ZR10
DCGT 070202-AL	7,75	2,38	6,35	0,2	●									○
DCGT 070204-AL	7,75	2,38	6,35	0,4	●									○
DCGT 11T302-AL	11,60	3,97	9,52	0,2	●									○
DCGT 11T304-AL	11,60	3,97	9,52	0,4	●									○
DCGT 11T308-AL	11,60	3,97	9,52	0,8	●									○

Positive 7° clearance - 55° rhombic insert.

Normally available for immediate delivery ●
Only available in a limited quantity ○

DCGT-AP	l	s	d	r	KM15	PM25	PM40	NC25	TiN16	TiN17	TiN22	TiN32	TiN35	ZR10
DCGT 070202-AP	7,75	2,38	6,35	0,2	●									○
DCGT 070204-AP	7,75	2,38	6,35	0,4	●									○
DCGT 11T302-AP	11,60	3,97	9,52	0,2	●									○
DCGT 11T304-AP	11,60	3,97	9,52	0,4	●									○
DCGT 11T308-AP	11,60	3,97	9,52	0,8	●									○

Positive 7° clearance - 55° rhombic insert.

Normally available for immediate delivery ●
Only available in a limited quantity ○

DCMT-03	l	s	d	r	KM15	PM25	PM40	NC25	TiN16	TiN17	TiN22	TiN32	TiN35	ZR10
DCMT 070204-03	7,75	2,38	6,35	0,4	○	●		●	●			●	●	
DCMT 11T304-03	11,60	3,97	9,52	0,4	○	●		●	●			●	●	
DCMT 11T308-03	11,60	3,97	9,52	0,8		○		●	●			●	●	
DCMT 150408-03	15,50	4,76	12,70	0,8		○			○					

Positive 7° clearance - 55° rhombic insert.

Normally available for immediate delivery ●
Only available in a limited quantity ○

DCMW	l	s	d	r	KM15	PM25	PM40	NC25	TiN16	TiN17	TiN22	TiN32	TiN35	ZR10
DCMW 11T304	11,60	3,97	9,52	0,4	●									
DCMW 11T308	11,60	3,97	9,52	0,8	●									
DCMW 150408	15,50	4,76	12,70	0,8	●									

- Inserts
- General turning
- Aluminum wheel turning
- Automatic lathes
- Ceramic tools
- Parting and grooving
- Threading
- Drills
- Cartridges
- Brazed tools
- Tooling

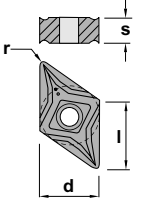
	Negative 55° rhombic insert.					Normally available for immediate delivery ●														
						Only available in a limited quantity ○														
	DNGP					l	s	d	r	KM15	PM25	PM40	NC25	TIN16	TIN17	TIN22	TIN32	TIN35	ZR10	
	DNGP 150404					15,50	4,76	12,70	0,4					●						
	DNGP 150408					15,50	4,76	12,70	0,8					●						

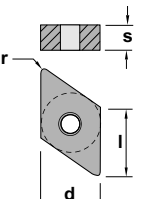
	Negative 55° rhombic insert.					Normally available for immediate delivery ●														
						Only available in a limited quantity ○														
	DNMA					l	s	d	r	KM15	PM25	PM40	NC25	TIN16	TIN17	TIN22	TIN32	TIN35	ZR10	
	DNMA 150608					15,50	6,35	12,70	0,8					○						
	DNMA 150612					15,50	6,35	12,70	1,2					○						

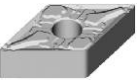
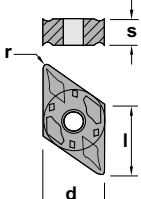
	Negative 55° rhombic insert.					Normally available for immediate delivery ●													
						Only available in a limited quantity ○													
	DNMG-CF					l	s	d	r	KM15	PM25	PM40	NC25	TIN16	TIN17	TIN22	TIN32	TIN35	ZR10
	DNMG 150604-CF					15,50	6,35	12,70	0,4				●			●			

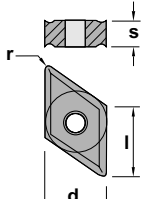
	Negative 55° rhombic insert					Normally available for immediate delivery ●													
						Only available in a limited quantity ○													
	DNMG-CFC					l	s	d	r	KM15	PM25	PM40	NC25	TIN16	TIN17	TIN22	TIN32	TIN35	ZR10
	DNMG 150404-CFC					15,50	4,76	12,70	0,4				●						

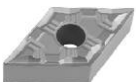
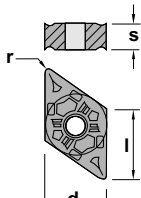
	Negative 55° rhombic insert.					Normally available for immediate delivery ●														
						Only available in a limited quantity ○														
	DNMG-CFM					l	s	d	r	KM15	PM25	PM40	NC25	TIN16	TIN17	TIN22	TIN32	TIN35	ZR10	
	DNMG 150404-CFM					15,50	4,76	12,70	0,4				●			●				
	DNMG 150604-CFM					15,50	6,35	12,70	0,4				●							

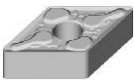
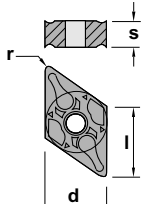
	Negative 55° rhombic insert.					Normally available for immediate delivery ● Only available in a limited quantity ○									
	DNMG-CM	l	s	d	r	KM15	PM25	PM40	NC25	TIN16	TIN17	TIN22	TIN32	TIN35	ZR10
	DNMG 150608-CM	15,50	6,35	12,70	0,8					●			●		

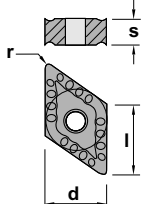
	Negative 55° rhombic insert					Normally available for immediate delivery ● Only available in a limited quantity ○									
	DNMG-CMC	l	s	d	r	KM15	PM25	PM40	NC25	TIN16	TIN17	TIN22	TIN32	TIN35	ZR10
	DNMG 150408-CMC	15,50	4,76	12,70	0,8				●						

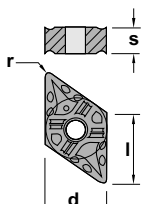
	Negative 55° rhombic insert					Normally available for immediate delivery ● Only available in a limited quantity ○									
	DNMG-CMF	l	s	d	r	KM15	PM25	PM40	NC25	TIN16	TIN17	TIN22	TIN32	TIN35	ZR10
	DNMG 150608-CMF	15,50	6,35	12,70	0,8					●			●		

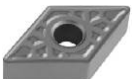
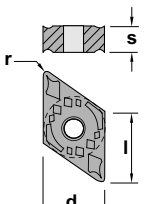
	Negative 55° rhombic insert.					Normally available for immediate delivery ● Only available in a limited quantity ○									
	DNMG-CMR	l	s	d	r	KM15	PM25	PM40	NC25	TIN16	TIN17	TIN22	TIN32	TIN35	ZR10
	DNMG 110404-CMR	11,60	4,76	9,52	0,4					●					
	DNMG 110408-CMR	11,60	4,76	9,52	0,8							●			
	DNMG 150408-CMR	15,50	4,76	12,70	0,8							●			
	DNMG 150608-CMR	15,50	6,35	12,70	0,8							●	●		
	DNMG 150612-CMR	15,50	6,35	12,70	1,2							●	●		
	DNMG 190608-CMR	19,40	6,35	15,88	0,8						○	○			
	DNMG 190612-CMR	19,40	6,35	15,88	1,2						○	○			

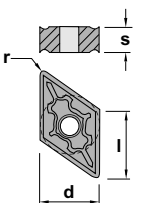
	Negative 55° rhombic insert.					Normally available for immediate delivery ● Only available in a limited quantity ○									
	DNMG-CS	l	s	d	r	KM15	PM25	PM40	NC25	TIN16	TIN17	TIN22	TIN32	TIN35	ZR10
	DNMG 110404-CS	11,60	4,76	9,52	0,4									●	
	DNMG 110408-CS	11,60	4,76	9,52	0,8									●	
	DNMG 150604-CS	15,50	6,35	12,70	0,4									●	
	DNMG 150608-CS	15,50	6,35	12,70	0,8									●	

Inserts
General turning
Aluminum wheel turning
Automatic lathes
Ceramic tools
Parting and grooving
Threading
Drills
Cartridges
Brazed tools
Tooling

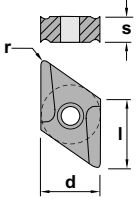
	Negative 55° rhombic insert.					Normally available for immediate delivery ● Only available in a limited quantity ○									
	DNMX	l	s	d	r	KM15	PM25	PM40	NC25	TIN16	TIN17	TIN22	TIN32	TIN35	ZR10
	DNMX 150604R-22	6,57	2,38	6,35	0,4					●				●	
DNMX 150608R-22	8,20	3,18	7,93	0,4					●				●		
															

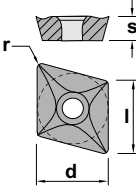
	Positive 7° clearance - 75° rhombic insert.					Normally available for immediate delivery ● Only available in a limited quantity ○									
	ECMT	l	s	d	r	KM15	PM25	PM40	NC25	TIN16	TIN17	TIN22	TIN32	TIN35	ZR10
	ECMT 060204	6,57	2,38	6,35	0,4					●					
ECMT 080304	8,20	3,18	7,93	0,4					●						
ECMT 120404	12,40	4,00	12,00	0,4					●						
ECMT 120408	12,40	4,00	12,00	0,8	○	○			●						
ECMT 120412	12,40	4,00	12,00	1,2		○			●						
															

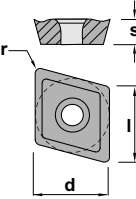
	Positive 11° clearance - 75° rhombic insert.					Normally available for immediate delivery ● Only available in a limited quantity ○									
	EPMT	l	s	d	r	KM15	PM25	PM40	NC25	TIN16	TIN17	TIN22	TIN32	TIN35	ZR10
	EPMT 080302-30	8,28	3,00	8,00	0,2		○								
EPMT 080304-30	8,28	3,00	8,00	0,4		●			●						
EPMT 080308-30	8,28	3,00	8,00	0,8		●			●						
															

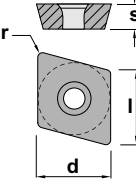
	Positive 11° clearance - 75° rhombic insert.					Normally available for immediate delivery ● Only available in a limited quantity ○									
	EPMW	l	s	d	r	KM15	PM25	PM40	NC25	TIN16	TIN17	TIN22	TIN32	TIN35	ZR10
	EPMW 040204	4,92	2,38	4,76	0,4		●			●					
EPMW 080304	8,28	3,00	8,00	0,4		○									
EPMW 080308	8,28	3,00	8,00	0,8		○									
															

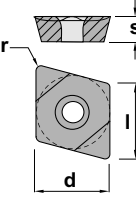
	Positive 11° clearance - 75° rhombic insert.					Normally available for immediate delivery ● Only available in a limited quantity ○									
	EPMX	l	s	d	r	KM15	PM25	PM40	NC25	TIN16	TIN17	TIN22	TIN32	TIN35	ZR10
	EPMX 040204	4,92	2,38	4,76	0,4		●								
															

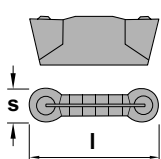
	Double ended insert						Normally available for immediate delivery ● Only available in a limited quantity ○													
	GXGP-AL						l	s	d	r	KM15	PM25	PM40	NC25	TIN16	TIN17	TIN22	TIN32	TIN35	ZR10
	GXGP-253.0-AL						-	3,18	8,00	-	●									○
	GXGP-254.0-AL						-	3,18	10,00	-	●									

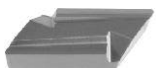
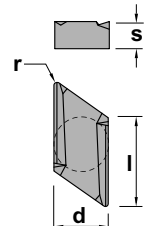
	Negative KNUX insert						Normally available for immediate delivery ● Only available in a limited quantity ○														
	KNUX						l	s	d	r	KM15	PM25	PM40	NC25	TIN16	TIN17	TIN22	TIN32	TIN35	ZR10	
	KNUX 160405L-21						16,00	4,76	9,52	0,5		●			●			●			
	KNUX 160405L-32						16,00	4,76	9,52	0,5		●			●						
	KNUX 160405R-21						16,00	4,76	9,52	0,5		●			●				●		
	KNUX 160405R-32						16,00	4,76	9,52	0,5		●			●						
	KNUX 160410L-21						16,00	4,76	9,52	1,0		●							●		
	KNUX 160410L-32						16,00	4,76	9,52	1,0		●							●		
	KNUX 160410R-21						16,00	4,76	9,52	1,0		●			○				●		
	KNUX 160410R-32						16,00	4,76	9,52	1,0		●						●			

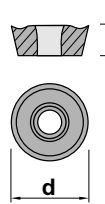
	Positive 7° clearance - Round insert.						Normally available for immediate delivery ● Only available in a limited quantity ○													
	RCGT-AL						l	s	d	r	KM15	PM25	PM40	NC25	TIN16	TIN17	TIN22	TIN32	TIN35	ZR10
	RCGT 0803M0-AL						-	3,18	8,00	-	●									○
	RCGT 1003M0-AL						-	3,18	10,00	-	●									

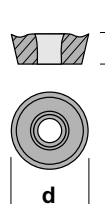
	Positive 7° clearance - Round insert.						Normally available for immediate delivery ● Only available in a limited quantity ○													
	RCGT-AP						l	s	d	r	KM15	PM25	PM40	NC25	TIN16	TIN17	TIN22	TIN32	TIN35	ZR10
	RCGT 0803M0-AP						-	3,18	8,00	-	●									○

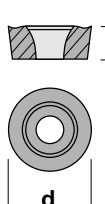
	Positive 7° clearance - Round insert.						Normally available for immediate delivery ● Only available in a limited quantity ○														
	RCMT						l	s	d	r	KM15	PM25	PM40	NC25	TIN16	TIN17	TIN22	TIN32	TIN35	ZR10	
	RCMT 0602M0						-	2,38	6,00	-				●							
	RCMT 0803M0						-	3,18	8,00	-				●							
	RCMT 1003M0						-	3,18	10,00	-				●							
	RCMT 10T3M0						-	3,97	10,00	-				●							
	RCMT 1204M0						-	4,76	12,00	-	○	●			●						
	RCMT 1606M0-30						-	6,35	16,00	-		○									
	RCMT 2006M0-30						-	6,35	20,00	-		○									

- Inserts
- General turning
- Aluminum wheel turning
- Automatic lathes
- Ceramic tools
- Parting and grooving
- Threading
- Drills
- Cartridges
- Brazed tools
- Tooling

Negative round insert. Normally available for immediate delivery ●
Only available in a limited quantity ○

RNMG

	l	s	d	r	KM15	PM25	PM40	NC25	TIN16	TIN17	TIN22	TIN32	TIN35	ZR10
RNMG 090300	-	3,18	9,52	-		○					○			
RNMG 120400	-	4,76	12,70	-		○					○			
RNMG 150600	-	6,35	15,88	-								○		
RNMG 190600	-	6,35	19,05	-								○		
RNMG 250900	-	9,52	25,40	-								○		

Positive 7° clearance - Square insert. Normally available for immediate delivery ●
Only available in a limited quantity ○

SCGT-AL

	l	s	d	r	KM15	PM25	PM40	NC25	TIN16	TIN17	TIN22	TIN32	TIN35	ZR10
SCGT 09T304-AL	9,52	3,97	9,52	0,4	●									○
SCGT 09T308-AL	9,52	3,97	9,52	0,8	●									○
SCGT 120408-AL	12,70	4,76	12,70	0,8	●									○

Positive 7° clearance - Square insert. Normally available for immediate delivery ●
Only available in a limited quantity ○

SCMT-03

	l	s	d	r	KM15	PM25	PM40	NC25	TIN16	TIN17	TIN22	TIN32	TIN35	ZR10
SCMT 09T304-03	9,52	3,97	9,52	0,4	○	●			○					
SCMT 09T308-03	9,52	3,97	9,52	0,8	○	●			●					
SCMT 120408-03	12,70	4,76	12,70	0,8		●			●					
SCMT 120412-03	12,70	4,76	12,70	1,2		●			○					

Positive 7° clearance - Square insert. Normally available for immediate delivery ●
Only available in a limited quantity ○

SCMT-39

	l	s	d	r	KM15	PM25	PM40	NC25	TIN16	TIN17	TIN22	TIN32	TIN35	ZR10
SCMT 09T304-39	9,52	3,97	9,52	0,4		●								
SCMT 09T308-39	9,52	3,97	9,52	0,8	○	●								
SCMT 120404-39	12,70	4,76	12,70	0,4		●								
SCMT 120408-39	12,70	4,76	12,70	0,8	○	●								
SCMT 120412-39	12,70	4,76	12,70	1,2		●								
SCMT 120508-39	12,70	5,00	12,70	0,8		●								
SCMT 120612-39	12,70	6,35	12,70	1,2		●								

Positive 7° clearance - Square insert. Normally available for immediate delivery ●
Only available in a limited quantity ○

SCMW

	l	s	d	r	KM15	PM25	PM40	NC25	TIN16	TIN17	TIN22	TIN32	TIN35	ZR10
SCMW 09T308	9,52	3,97	9,52	0,8		○								
SCMW 120408	12,70	4,76	12,70	0,8	○	○								
SCMW 120412	12,70	4,76	12,70	1,2		○								

Negative square insert. Normally available for immediate delivery ●
Only available in a limited quantity ○

SNMA

	l	s	d	r	KM15	PM25	PM40	NC25	TIN16	TIN17	TIN22	TIN32	TIN35	ZR10
SNMA 120404	12,70	4,76	12,70	0,4						○				
SNMA 120408	12,70	4,76	12,70	0,8						○				
SNMA 120412	12,70	4,76	12,70	1,2						○				
SNMA 120416	12,70	4,76	12,70	1,6						○				
SNMA 190612	19,05	6,35	19,05	1,2						○				
SNMA 190616	19,05	6,35	19,05	1,6						○				

Negative square insert. Normally available for immediate delivery ●
Only available in a limited quantity ○

SNMG-CFM

	l	s	d	r	KM15	PM25	PM40	NC25	TIN16	TIN17	TIN22	TIN32	TIN35	ZR10
SNMG 120404-CFM	12,70	4,76	12,70	0,4					●					

Negative square insert. Normally available for immediate delivery ●
Only available in a limited quantity ○

SNMG-CMR

	l	s	d	r	KM15	PM25	PM40	NC25	TIN16	TIN17	TIN22	TIN32	TIN35	ZR10
SNMG 120408-CMR	12,70	4,76	12,70	0,8		○					●	●		

Negative square insert. Normally available for immediate delivery ●
Only available in a limited quantity ○

SNMG-CR

	l	s	d	r	KM15	PM25	PM40	NC25	TIN16	TIN17	TIN22	TIN32	TIN35	ZR10
SNMG 120412-CR	12,70	4,76	12,70	1,2								●		
SNMG 150612-CR	15,88	6,35	15,88	1,2								○		
SNMG 190616-CR	19,05	6,35	19,05	1,6								○		
SNMG 250724-CR	25,40	7,94	25,40	2,4								○		

Negative square insert. Normally available for immediate delivery ●
Only available in a limited quantity ○

SNMM

	l	s	d	r	KM15	PM25	PM40	NC25	TIN16	TIN17	TIN22	TIN32	TIN35	ZR10
SNMM 190612	19,05	6,35	19,05	1,2								○		
SNMM 190616	19,05	6,35	19,05	1,6								○		
SNMM 250724	25,40	7,94	25,40	2,4								○		

- Inserts
- General turning
- Aluminum wheel turning
- Automatic lathes
- Ceramic tools
- Parting and grooving
- Threading
- Drills
- Cartridges
- Brazed tools
- Tooling

	Positive 11° clearance - Square insert.					Normally available for immediate delivery ●																				
						Only available in a limited quantity ○																				
SPMR-33											l	s	d	r	KM15	PM25	PM40	NC25	TIN16	TIN17	TIN22	TIN32	TIN35	ZR10		
SPMR 090304-33											9,52	3,18	9,52	0,4					●							
SPMR 090308-33											9,52	3,18	9,52	0,8							●					
SPMR 120304-33											12,70	3,18	12,70	0,4					●							
SPMR 120308-33											12,70	3,18	12,70	0,8		●					●					

	Positive 11° clearance - Square insert.					Normally available for immediate delivery ●																			
						Only available in a limited quantity ○																			
SPMT											l	s	d	r	KM15	PM25	PM40	NC25	TIN16	TIN17	TIN22	TIN32	TIN35	TL40	
SPMT 060304											6,35	3,18	6,35	0,4									●		●
SPMT 070308											7,94	3,18	7,94	0,8									●		●
SPMT 090308											9,52	3,18	9,52	0,8									●		●
SPMT 120408											12,70	4,76	12,70	0,8									●		●

	Positive 11° clearance - Square insert.					Normally available for immediate delivery ●																				
						Only available in a limited quantity ○																				
SPUN											l	s	d	r	KM15	PM25	PM40	NC25	TIN16	TIN17	TIN22	TIN32	TIN35	ZR10		
SPUN 090304E											9,52	3,18	9,52	0,4		○										
SPUN 090308E											9,52	3,18	9,52	0,8		●										
SPUN 090308F											9,52	3,18	9,52	0,8	○											
SPUN 120304E											12,70	3,18	12,70	0,4		●										
SPUN 120308E											12,70	3,18	12,70	0,8		●										
SPUN 120308F											12,70	3,18	12,70	0,8	●											
SPUN 120312E											12,70	3,18	12,70	1,2		●										
SPUN 120408E											12,70	4,76	12,70	0,8		○										
SPUN 150408E											15,88	4,76	15,88	0,8		○										
SPUN 150412E											15,88	4,76	15,88	1,2		○										
SPUN 190412E											19,05	4,76	19,05	1,2		○										

	Positive 7° clearance - Triangular insert for aluminium and soft materials. Extra positive cutting angle. Suitable for finishing stainless steel.					Normally available for immediate delivery ●																			
						Only available in a limited quantity ○																			
TCGT-AL											l	s	d	r	KM15	PM25	PM40	NC25	TIN16	TIN17	TIN22	TIN32	TIN35	ZR10	
TCGT 110202-AL											11,00	2,38	6,35	0,2	●										○
TCGT 110204-AL											11,00	2,38	6,35	0,4	●										○
TCGT 16T302-AL											16,50	3,97	9,52	0,2	●										○
TCGT 16T304-AL											16,50	3,97	9,52	0,4	●										○
TCGT 16T308-AL											16,50	3,97	9,52	0,8	●										○

	Positive 7° clearance - Triangular insert.					Normally available for immediate delivery ●																			
						Only available in a limited quantity ○																			
TCMT-03											l	s	d	r	KM15	PM25	PM40	NC25	TIN16	TIN17	TIN22	TIN32	TIN35	ZR10	
TCMT 090204-03											9,62	2,38	5,55	0,4	○				●						
TCMT 110204-03											11,00	2,38	6,35	0,4	●	●			●						
TCMT 16T304-03											16,50	3,97	9,52	0,4	○	●			●				●	●	
TCMT 16T308-03											16,50	3,97	9,52	0,8	●	●			●				●	●	
TCMT 220408-03											22,00	4,76	12,70	0,8		○									
TCMT 220412-03											22,00	4,76	12,70	1,2		○									

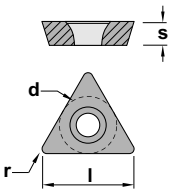
	Positive 7° clearance - Triangular insert.					Normally available for immediate delivery ● Only available in a limited quantity ○									
	TCMW	l	s	d	r	KM15	PM25	PM40	NC25	TIN16	TIN17	TIN22	TIN32	TIN35	ZR10
	TCMW 110204	11,00	2,38	6,35	0,4	○	●								
	TCMW 16T304	16,50	3,97	9,52	0,4	●	●								
	TCMW 16T308	16,50	3,97	9,52	0,8	●	●								

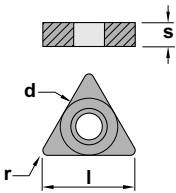
	Negative triangular insert.					Normally available for immediate delivery ● Only available in a limited quantity ○									
	TNMA	l	s	d	r	KM15	PM25	PM40	NC25	TIN16	TIN17	TIN22	TIN32	TIN35	ZR10
	TNMA 160404	16,50	4,76	9,52	0,4						○				
	TNMA 160408	16,50	4,76	9,52	0,8						○				
	TNMA 160412	16,50	4,76	9,52	1,2						○				
	TNMA 220408	22,00	4,76	12,70	0,8						○				
	TNMA 220412	22,00	4,76	12,70	1,2						○				
	TNMA 220416	22,00	4,76	12,70	1,6						○				

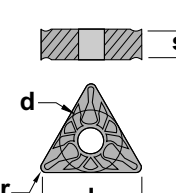
	Negative triangular insert.					Normally available for immediate delivery ● Only available in a limited quantity ○									
	TNMG-CF	l	s	d	r	KM15	PM25	PM40	NC25	TIN16	TIN17	TIN22	TIN32	TIN35	ZR10
	TNMG 160404-CF	16,50	4,76	9,52	0,4					●			●		

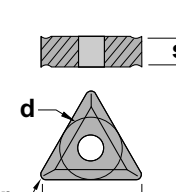
	Negative triangular insert					Normally available for immediate delivery ● Only available in a limited quantity ○									
	TNMG-CFC	l	s	d	r	KM15	PM25	PM40	NC25	TIN16	TIN17	TIN22	TIN32	TIN35	ZR10
	TNMG 160404-CFC	16,50	4,76	9,52	0,4				●						

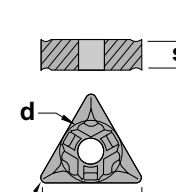
	Negative triangular insert.					Normally available for immediate delivery ● Only available in a limited quantity ○									
	TNMG-CFM	l	s	d	r	KM15	PM25	PM40	NC25	TIN16	TIN17	TIN22	TIN32	TIN35	ZR10
	TNMG 160404-CFM	16,50	4,76	9,52	0,4					●					
	TNMG 220404-CFM	22,00	4,76	12,70	0,4					●					

- Inserts
- General turning
- Aluminium wheel turning
- Automatic lathes
- Ceramic tools
- Parting and grooving
- Threading
- Drills
- Cartridges
- Brazed tools
- Tooling

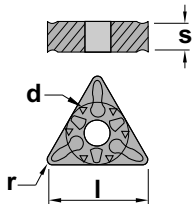
	Negative triangular insert.					Normally available for immediate delivery ● Only available in a limited quantity ○									
	TNMG-CM	l	s	d	r	KM15	PM25	PM40	NC25	TIN16	TIN17	TIN22	TIN32	TIN35	ZR10
	TNMG 160408-CM	16,50	4,76	9,52	0,8					●			●		

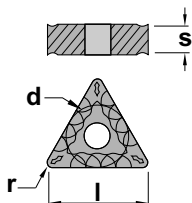
	Negative triangular insert.					Normally available for immediate delivery ● Only available in a limited quantity ○									
	TNMG-CMC	l	s	d	r	KM15	PM25	PM40	NC25	TIN16	TIN17	TIN22	TIN32	TIN35	ZR10
	TNMG 160408-CMC	16,50	4,76	9,52	0,8				●						

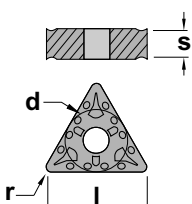
	Negative triangular insert.					Normally available for immediate delivery ● Only available in a limited quantity ○									
	TNMG-CMF	l	s	d	r	KM15	PM25	PM40	NC25	TIN16	TIN17	TIN22	TIN32	TIN35	ZR10
	TNMG 160408-CMF	16,50	4,76	9,52	0,8					●					

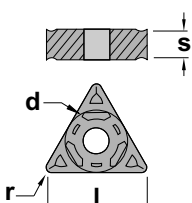
	Negative triangular insert.					Normally available for immediate delivery ● Only available in a limited quantity ○									
	TNMG-CMR	l	s	d	r	KM15	PM25	PM40	NC25	TIN16	TIN17	TIN22	TIN32	TIN35	ZR10
	TNMG 160408-CMR	16,50	4,76	9,52	0,8		●					●	●		
	TNMG 160412-CMR	16,50	4,76	9,52	1,2								●	●	
	TNMG 220408-CMR	22,00	4,76	12,70	0,8		○					●	●		
	TNMG 220412-CMR	22,00	4,76	12,70	1,2								●		

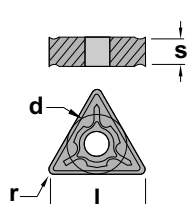
	Negative triangular insert.					Normally available for immediate delivery ● Only available in a limited quantity ○									
	TNMG-CS	l	s	d	r	KM15	PM25	PM40	NC25	TIN16	TIN17	TIN22	TIN32	TIN35	ZR10
	TNMG 160404-CS	16,50	4,76	9,52	0,4									●	
	TNMG 160408-CS	16,50	4,76	9,52	0,8									●	

Negative triangular insert. Normally available for immediate delivery ●
Only available in a limited quantity ○

TNMX

	l	s	d	r	KM15	PM25	PM40	NC25	TIN16	TIN17	TIN22	TIN32	TIN35	ZR10
TNMX 160404 R	16,50	4,76	9,52	0,4				●						
TNMX 160408 R	16,50	4,76	9,52	0,8				●						
TNMX 160404 L	16,50	4,76	9,52	0,4				●						
TNMX 160408 L	16,50	4,76	9,52	0,8				●						

Positive 11° clearance - Triangular insert. Normally available for immediate delivery ●
Only available in a limited quantity ○

TPMN

	l	s	d	r	KM15	PM25	PM40	NC25	TIN16	TIN17	TIN22	TIN32	TIN35	ZR10
TPMN 160308	16,50	3,18	9,52	0,8				●						

Positive 11° clearance - Triangular insert. Normally available for immediate delivery ●
Only available in a limited quantity ○

TPMR-33

	l	s	d	r	KM15	PM25	PM40	NC25	TIN16	TIN17	TIN22	TIN32	TIN35	ZR10
TPMR 090204-33	9,62	2,38	5,55	0,4					●					
TPMR 110304-33	11,00	3,18	6,35	0,4		●			●					
TPMR 110308-33	11,00	3,18	6,35	0,8		●					●			
TPMR 160304-33	16,50	3,18	9,52	0,4		●			●			●		
TPMR 160308-33	16,50	3,18	9,52	0,8		●			●			●		

Positive 11° clearance - Triangular insert. Normally available for immediate delivery ●
Only available in a limited quantity ○

TPUN

	l	s	d	r	KM15	PM25	PM40	NC25	TIN16	TIN17	TIN22	TIN32	TIN35	ZR10
TPUN 110204E	11,00	2,38	6,35	0,4		●								
TPUN 110204F	11,00	2,38	6,35	0,4	○	●								
TPUN 110208E	11,00	2,38	6,35	0,8		●								
TPUN 110304E	11,00	3,18	6,35	0,4		●								
TPUN 110308E	11,00	3,18	6,35	0,8		●								
TPUN 110308F	11,00	3,18	6,35	0,8	○	●								
TPUN 160304E	16,50	3,18	9,52	0,4		●			○					
TPUN 160304F	16,50	3,18	9,52	0,4	○	●								
TPUN 160308T	16,50	3,18	9,52	0,8		●								
TPUN 160308E	16,50	3,18	9,52	0,8		●			○					
TPUN 160308F	16,50	3,18	9,52	0,8	●	●								
TPUN 160312E	16,50	3,18	9,52	1,2		●								
TPUN 160312F	16,50	3,18	9,52	1,2	○	●								
TPUN 220408E	22,00	4,76	12,70	0,8		●								
TPUN 220408F	22,00	4,76	12,70	0,8	●	●								
TPUN 220412E	22,00	4,76	12,70	1,2		●								
TPUN 220412F	22,00	4,76	12,70	1,2	○	●								

- Inserts
- General turning
- Aluminum wheel turning
- Automatic lathes
- Ceramic tools
- Parting and grooving
- Threading
- Drills
- Cartridges
- Brazed tools
- Tooling

Positive 11° clearance - Triangular insert.

Normally available for immediate delivery ●
Only available in a limited quantity ○

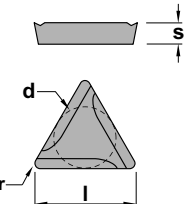
 TPUX		l	s	d	r	KM15	PM25	PM40	NC25	TiN16	TiN17	TiN22	TiN32	TiN35	ZR10
	TPUX 110304L	11,00	3,18	6,35	0,4	○	●								
	TPUX 110304R	11,00	3,18	6,35	0,4	○	●								
	TPUX 160304L	16,50	3,18	9,52	0,4	○	●								
	TPUX 160304R	16,50	3,18	9,52	0,4	○	●								
	TPUX 160308L	16,50	3,18	9,52	0,8	○	●								
	TPUX 160308R	16,50	3,18	9,52	0,8	○	●								
	TPUX 220408L	22,00	4,76	12,70	0,8	○	○								
	TPUX 220408R	22,00	4,76	12,70	0,8	○	○								

Positive 5° clearance - 35° rhombic insert.

Normally available for immediate delivery ●
Only available in a limited quantity ○

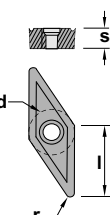
 VBMT		l	s	d	r	KM15	PM25	PM40	NC25	TiN16	TiN17	TiN22	TiN32	TiN35	ZR10
	VBMT 160404	16,50	4,76	9,52	0,4					●					
	VBMT 160408	16,50	4,76	9,52	0,8					●					

Positive 7° clearance - 35° rhombic insert.

Normally available for immediate delivery ●
Only available in a limited quantity ○

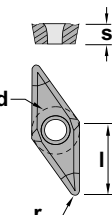
 VCGT-AL		l	s	d	r	KM15	PM25	PM40	NC25	TiN16	TiN17	TiN22	TiN32	TiN35	ZR10
	VCGT 160404-AL	16,50	4,76	9,52	0,4	●									○
	VCGT 160408-AL	16,50	4,76	9,52	0,8	●									○
	VCGT 160412-AL	16,50	4,76	9,52	1,2	●									○
	VCGT 220530-AL	22,10	5,56	12,70	3,0	●									○

Positive 7° clearance - 35° rhombic insert.

Normally available for immediate delivery ●
Only available in a limited quantity ○

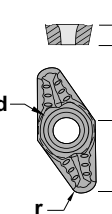
 VCGT-AP		l	s	d	r	KM15	PM25	PM40	NC25	TiN16	TiN17	TiN22	TiN32	TiN35	ZR10
	VCGT 160404-AP	16,50	4,76	9,52	0,4	●									○
	VCGT 160408-AP	16,50	4,76	9,52	0,8	●									○
	VCGT 160412-AP	16,50	4,76	9,52	1,2	●									○
	VCGT 220530-AP	22,10	5,56	12,70	3,0	●									○

Positive 7° clearance - 35° rhombic insert.

Normally available for immediate delivery ●
Only available in a limited quantity ○

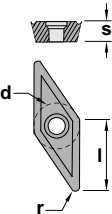
 VCMT-03		l	s	d	r	KM15	PM25	PM40	NC25	TiN16	TiN17	TiN22	TiN32	TiN35	ZR10
	VCMT 110304-03	11,00	3,18	6,35	0,4					●					
	VCMT 130304-03	13,00	3,18	8,00	0,4					●					
	VCMT 160404-03	16,50	4,76	9,52	0,4					●				●	
	VCMT 160408-03	16,50	4,76	9,52	0,8							●		●	

Negative 35° rhombic insert. Normally available for immediate delivery ●
Only available in a limited quantity ○

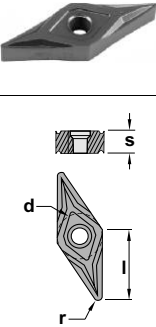
		l	s	d	r	KM15	PM25	PM40	NC25	TIN16	TIN17	TIN22	TIN32	TIN35	ZR10
	VNGP 160404	16,50	4,76	9,52	0,4						●				
	VNGP 160408	16,50	4,76	9,52	0,8						●				

Negative 35° rhombic insert. Normally available for immediate delivery ●
Only available in a limited quantity ○

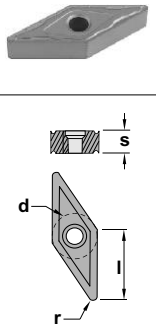
		l	s	d	r	KM15	PM25	PM40	NC25	TIN16	TIN17	TIN22	TIN32	TIN35	ZR10
	VNMG 160408	16,50	4,76	9,52	0,8					●					
	VNMG 220408	22,00	4,76	12,70	0,8							●			

Negative 35° rhombic insert. Normally available for immediate delivery ●
Only available in a limited quantity ○

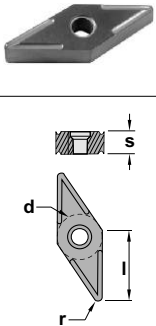
		l	s	d	r	KM15	PM25	PM40	NC25	TIN16	TIN17	TIN22	TIN32	TIN35	ZR10
	VNMG 160404-CMC	16,50	4,76	9,52	0,4				●						
	VNMG 160408-CMC	16,50	4,76	9,52	0,8				●						

Positive 7° clearance - 80° Trigon insert. Normally available for immediate delivery ●
Only available in a limited quantity ○

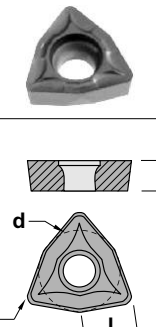
		l	s	d	r	KM15	PM25	PM40	NC25	TIN16	TIN17	TIN22	TIN32	TIN35	ZR10
	WCMT 030204	3,46	2,38	5,56	0,4								●		
	WCMT 040204	3,99	2,38	6,35	0,4								●		
	WCMT 050308	5,07	3,18	7,94	0,8								●		
	WCMT 06T308	6,14	3,97	9,52	0,8								●		

Positive 7° clearance - 80° Trigon insert. Normally available for immediate delivery ●
Only available in a limited quantity ○

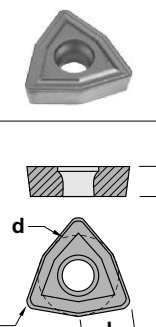
		l	s	d	r	KM15	PM25	PM40	NC25	TIN16	TIN17	TIN22	TIN32	TIN35	ZR10
	WCMX 030208	3,46	2,38	5,56	0,8			●					●		
	WCMX 040208	3,99	2,38	6,35	0,8			●					●		
	WCMX 050308	5,07	3,18	7,94	0,8			●					●		
	WCMX 06T308	6,14	3,97	9,52	0,8			●					●		
	WCMX 080412	8,14	4,76	12,70	1,2			●					●		

- Inserts
- General turning
- Aluminum wheel turning
- Automatic lathes
- Ceramic tools
- Parting and grooving
- Threading
- Drills
- Cartridges
- Brazed tools
- Tooling

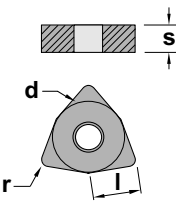
	Negative 80° trigon insert.					Normally available for immediate delivery ● Only available in a limited quantity ○													
	WNMA					l	s	d	r	KM15	PM25	PM40	NC25	TIN16	TIN17	TIN22	TIN32	TIN35	ZR10
	WNMA 080408					8,14	4,76	12,70	0,8					○					
	WNMA 080412					8,14	4,76	12,70	1,2					○					

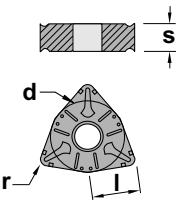
	Negative 80° trigon insert.					Normally available for immediate delivery ● Only available in a limited quantity ○													
	WNMG-CF					l	s	d	r	KM15	PM25	PM40	NC25	TIN16	TIN17	TIN22	TIN32	TIN35	ZR10
	WNMG 080404-CF					8,14	4,76	12,70	0,4				●			●			

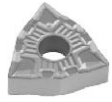
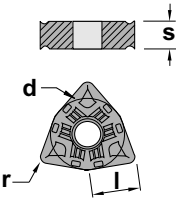
	Negative 80° trigon insert.					Normally available for immediate delivery ● Only available in a limited quantity ○													
	WNMG-CFM					l	s	d	r	KM15	PM25	PM40	NC25	TIN16	TIN17	TIN22	TIN32	TIN35	ZR10
	WNMG 080404-CFM					8,14	4,76	12,70	0,4				●						

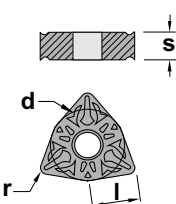
	Negative 80° trigon insert.					Normally available for immediate delivery ● Only available in a limited quantity ○													
	WNMG-CM					l	s	d	r	KM15	PM25	PM40	NC25	TIN16	TIN17	TIN22	TIN32	TIN35	ZR10
	WNMG 080408-CM					8,14	4,76	12,70	0,8				●			●			

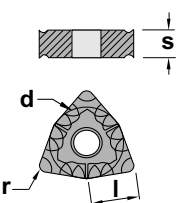
	Negative 80° trigon insert.					Normally available for immediate delivery ● Only available in a limited quantity ○													
	WNMG-CMC					l	s	d	r	KM15	PM25	PM40	NC25	TIN16	TIN17	TIN22	TIN32	TIN35	ZR10
	WNMG 080408-CMC					8,14	4,76	12,70	0,8				●						

Negative 80° trigon insert. Normally available for immediate delivery ●
Only available in a limited quantity ○

WNMG-CMF

	l	s	d	r	KM15	PM25	PM40	NC25	TIN16	TIN17	TIN22	TIN32	TIN35	ZR10
WNMG 080408-CMF	8,14	4,76	12,70	0,8					●					

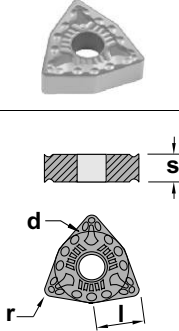

Negative 80° trigon insert. Normally available for immediate delivery ●
Only available in a limited quantity ○

WNMG-CMR

	l	s	d	r	KM15	PM25	PM40	NC25	TIN16	TIN17	TIN22	TIN32	TIN35	ZR10
WNMG 060404-CMR	6,45	4,76	9,52	0,4					●					
WNMG 060408-CMR	6,45	4,76	9,52	0,8							●			
WNMG 080408-CMR	8,14	4,76	12,70	0,8							●	●		
WNMG 080412-CMR	8,14	4,76	12,70	1,2							●			

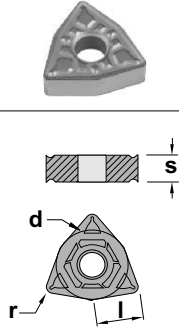

Negative 80° trigon insert. Normally available for immediate delivery ●
Only available in a limited quantity ○

WNMG-CS

	l	s	d	r	KM15	PM25	PM40	NC25	TIN16	TIN17	TIN22	TIN32	TIN35	ZR10
WNMG 060404-CS	6,45	4,76	9,52	0,4									●	
WNMG 060408-CS	6,45	4,76	9,52	0,8									●	
WNMG 080408-CS	8,14	4,76	12,70	0,8									●	
WNMG 080412-CS	8,14	4,76	12,70	1,2									●	

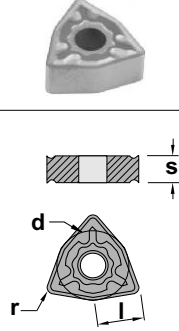

- Inserts
- General turning
- Aluminium wheel turning
- Automatic lathes
- Ceramic tools
- Parting and grooving
- Threading
- Drills
- Cartridges
- Braze tools
- Tooling

Turning insert wear and tool life

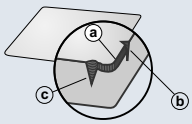
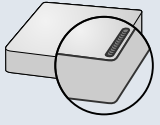
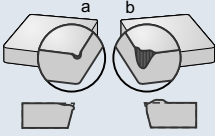
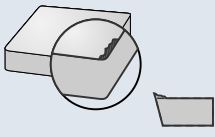
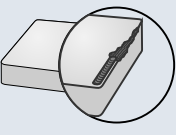
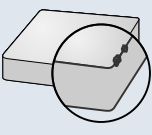
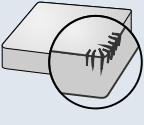
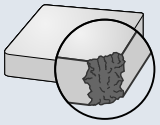
	Problem	Cause and Remedy
<p>Flank and notch wear</p> 	<ul style="list-style-type: none"> ★ Rapid flank wear causing poor surface finish or out of tolerance (a). ★ Notch wear causing poor surface finish and risk of 	<ul style="list-style-type: none"> ☆ A too high cutting speed or insufficient wear resistance (a). ☆ Oxidation or excessive attrition wear caused by a hard surface (b,c) <p>Reduce the cutting speed. Select a more wear resistant grade. Select an Al₂O₃ coated grade for steel machining.</p>
<p>Crater wear</p> 	<ul style="list-style-type: none"> ★ Excessive crater wear causing a weakened edge. Cutting edge break through on the trailing edge causes poor surface finish. 	<ul style="list-style-type: none"> ☆ Diffusion wear due to too high cutting temperatures on the rake face. <p>Select an Al₂O₃ coated grade. Select a positive insert geometry.</p>
<p>Plastic deformation</p> 	<ul style="list-style-type: none"> ★ Plastic deformation (edge depression (a) or flank impression (b)) leading to poor chip control and poor surface finish. Risk of excessive flank wear leading 	<ul style="list-style-type: none"> ☆ A too high cutting temperature in combination with a high pressure. <p>Select a harder grade with better resistance to plastic deformation. (a) Reduce cutting speed.</p>
<p>Built-up edge</p> 	<ul style="list-style-type: none"> ★ Built-up edge (B.U.E.) causing poor surface finish and cutting edge chattering when the B.U.E. is torn away. 	<ul style="list-style-type: none"> ☆ Workpiece material is welded to the insert due to: <ul style="list-style-type: none"> -low cutting speed. -relative cutting geometry. -"sticky" material, e.g. certain stainless steels and pure aluminium. <p>Increase cutting speed. Select a positive geometry. Increase cutting speed drastically. If tool life turns out to be short, apply</p>
<p>Chip hammering</p> 	<ul style="list-style-type: none"> ★ The part of the cutting edge not in cut is damaged through chip hammering. Both the top side and the support for the insert, can be damaged. 	<ul style="list-style-type: none"> ☆ The chips are of an excessive length and are deflected against the cutting edge. <p>Change the feed slightly. Select an alternative insert geometry.</p>
<p>Frittering</p> 	<ul style="list-style-type: none"> ★ Small cutting edge fractures (frittering) causing poor surface finish and excessive flank wear. 	<ul style="list-style-type: none"> ☆ Grade too brittle. ☆ Insert geometry too weak. ☆ Built-up edge. <p>Select a tougher grade. Select an insert with a stronger geometry. Increase cutting speed or select a positive geometry.</p>
<p>Thermal cracks</p> 	<ul style="list-style-type: none"> ★ Small cracks perpendicular to the cutting edge causing frittering and poor surface finish. 	<ul style="list-style-type: none"> ☆ Thermal cracks due to temperature variations caused by: <ul style="list-style-type: none"> -Intermittent machining. -Varying coolant supply. <p>Select a tougher grade with better resistant to thermal shocks.</p>
<p>Insert breakage</p> 	<ul style="list-style-type: none"> ★ Insert breakage that damages not only the insert but also the shim and workpiece. 	<ul style="list-style-type: none"> ☆ Grade too brittle. ☆ Excessive load on the insert. ☆ Insert geometry too weak. ☆ Insert size is too small. <p>Select a tougher grade. Reduce the feed and/or the depth of the cut. Select a stronger geometry, preferably a single sided insert. Select a thicker/larger insert.</p>

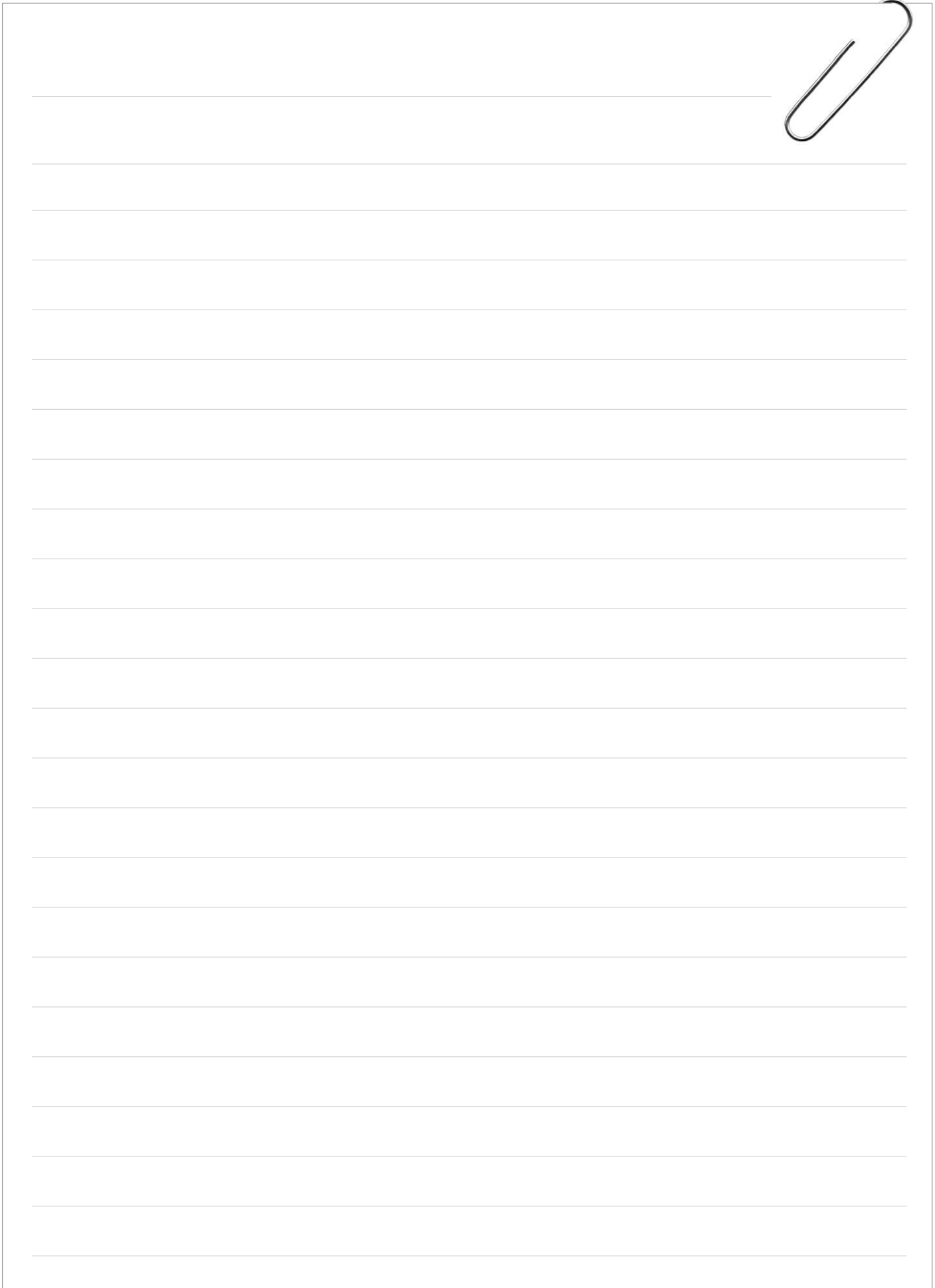

A large rectangular area with horizontal lines for writing. In the top right corner, there is a paperclip icon.

Inserts
General turning
Aluminium wheel turning
Automatic lathes
Ceramic tools
Parting and grooving
Threading
Drills
Cartridges
Brazed tools
Tooling